

Igo T 70 A

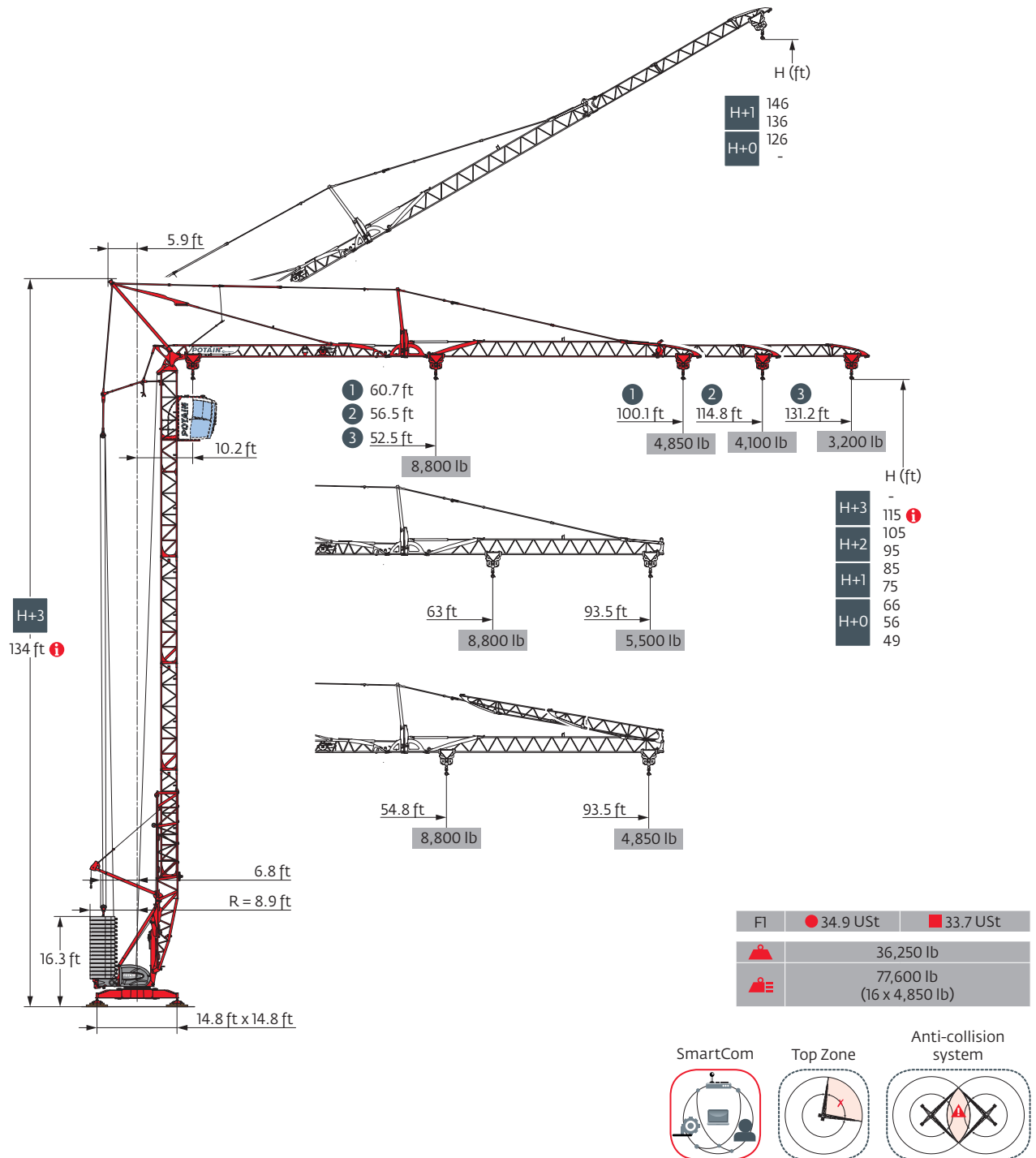

Load curves

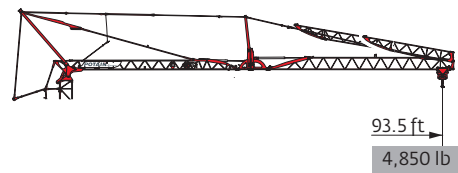
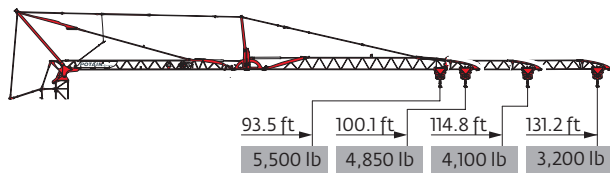

131 ft	10.2	▶	52.5	59.1	65.6	72.2	78.7	85.3	85.8	91.9	98.4	105	111.5	118.1	124.7	131.2	ft	
▲▲▲			8,800	7,650	6,700	6,000	5,400	4,900	-	4,450	4,100	3,800	3,500	3,250	3,050	2,850	lb	
										4,850	4,450	4,100	3,800	3,500	3,250	3,050	2,850	lb
											4,850	4,450	4,150	3,850	3,600	3,400	3,200	lb

115 ft	10.2	▶	56.5	59.1	65.6	72.2	78.7	85.3	91.9	92.9	98.4	98.9	105	111.5	114.8	ft
▲▲▲			8,800	8,350	7,350	6,550	5,900	5,400	4,900	-	4,500	-	4,200	3,900	3,750	lb
										4,850	4,500	-	4,200	3,900	3,750	lb
											4,850	4,500	4,200	4,100		lb

100 ft	10.2	▶	60.7	65.6	72.2	78.7	85.3	91.9	98.4	100.1	ft
▲▲▲			8,800	8,050	7,150	6,450	5,850	5,350	4,950	4,850	lb
										4,850	lb
										4,850	lb

94 ft	10.2	▶	63	65.6	72.2	78.7	85.3	91.9	93.5	ft
▲▲▲			8,800	8,400	7,500	6,750	6,150	5,650	5,500	lb
									4,850	lb
									4,850	lb

131 ft	10.2	▶	54.8	59.1	65.6	72.2	78.7	85.3	90	91.9	93.5	ft
▲▲▲			8,800	8,050	7,100	6,350	5,700	5,150	-	4,750	4,650	lb
									4,850	4,750	4,650	lb
										4,850		lb

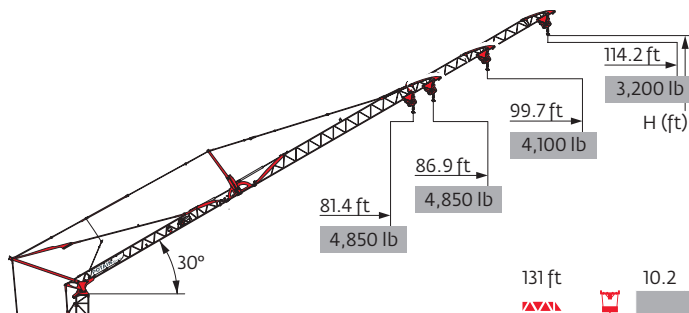

▲▲▲	131 ft	115 ft	100 ft	94 ft
H+1	146	138	-	-
H+0	136	128	120	117

131 ft	10.2	▶	75.5	78.7	80.1	85.3	91.9	98.4	105	114.2	ft	
▲▲▲			4,850	4,550	-	4,150	3,750	3,450	3,200	2,850	lb	
						4,850	4,500	4,150	3,800	3,550	3,200	lb

115 ft	10.2	▶	80.9	85.3	86	91.9	99.7	ft	
▲▲▲			4,850	4,550	-	4,150	3,750	lb	
						4,850	4,500	4,100	lb

100 ft	10.2	▶	86.9	ft
▲▲▲			4,850	lb
			4,850	lb





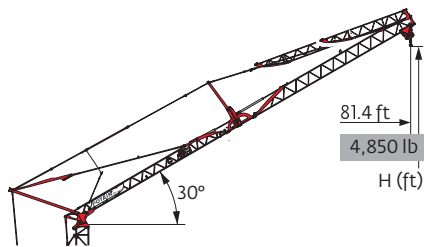

94 ft	10.2	▶	81.4	ft
▲▲▲			4,850	lb
			4,850	lb





▲▲▲	131 ft
	115 ft
H+1	-
H+0	107



131 ft	10.2	▶	81.4	ft
▲▲▲			4,850	lb
			4,850	lb

Mechanisms

480 V - 60 Hz												hp	kW	
	15 LVF 11 Optima	fpm	11	59	98	118	223	6	30	49	59	112	15	11
		lb	4,850	4,850	4,850	3,300	1,210	8,800	8,800	8,800	6,600	2,420		
	3 DVF 5	fpm	49 - 98 - 135 (2,850 → 8,800 lb) 49 - 98 - 148 (0 → 2,850 lb)									3	2.2	
	RVF 151 Optima+	rpm	0 → 0.8									5.5	4	
														

 IEC 60204-32	 kVA
480 V (+6% -10%) 60 Hz	 → 17 kVA  → 19 kVA

15 LVF 11 Optima

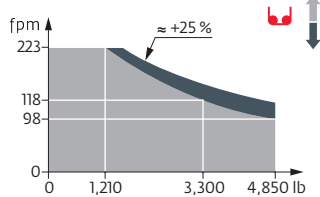

Erection

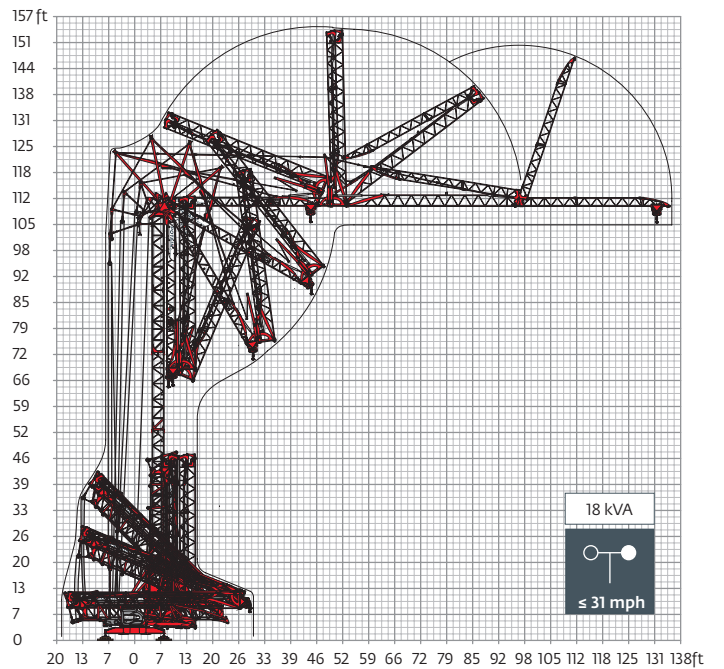
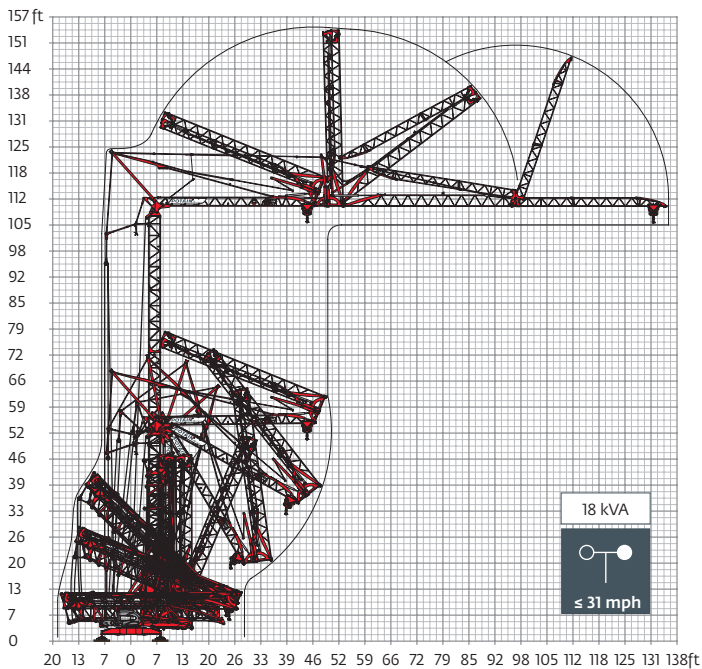

Transport

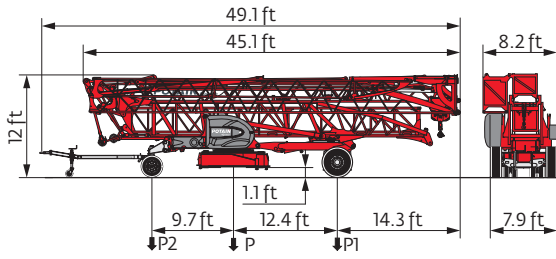

	mph	P (lb)	P1 (lb)	P2 (lb)
DJ100/S120	6	37,410	21,030	16,380
DJ105/S125	15.5	38,050	21,500	16,550

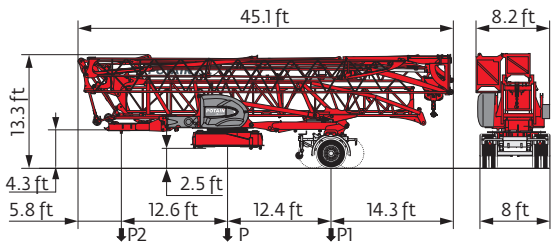

	mph	P (lb)	P1 (lb)	P2 (lb)
SL121/J135	15.5	39,280	25,410	13,870

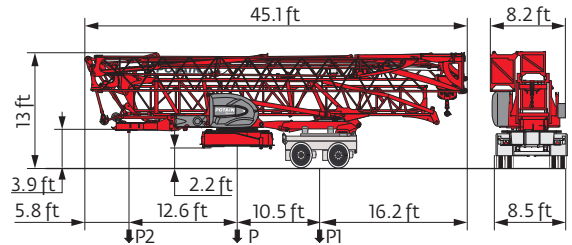

	P (lb)	P1 (lb)	P2 (lb)
North America Highway Axle	39,440	27,230	12,210

- R Rear slewing radius
- i Consult us
- Reactions in service
- Reactions out of service
- ⚖ Weight without load, without ballast, without transport axles, with max. jib and standard height
- ⚖ Total ballast weight
- Standard equipment
- Options
- Hoisting
- Trolleying
- Slewing
- Travelling
- kVA Required power

⚠ This commercial document is not legally binding. For any technical information, please refer to the corresponding instructions.



BRONSON CRANE

801-963-7850

P.O. Box 2048
West Jordan, UT 84084

bronsoncrane.com



© 2020 The Manitowoc Company, Inc.
www.manitowoc.com