

Technical data
Hydraulic lift crane

LR 1160
Litronic®

Complies with ANSI B 30.5

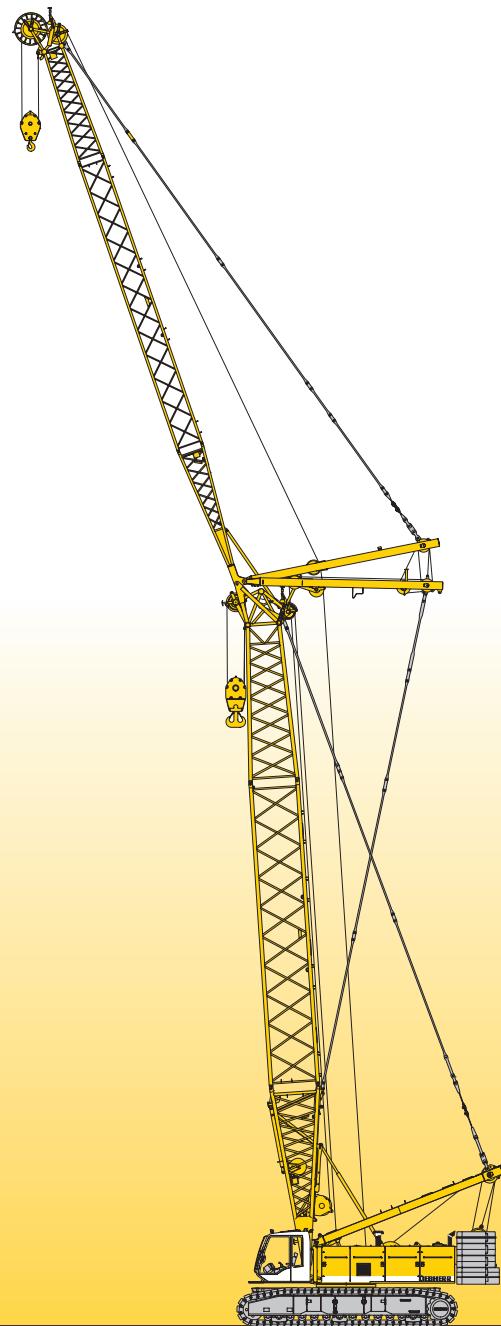

LIEBHERR

Dimensions

Basic machine with undercarriage

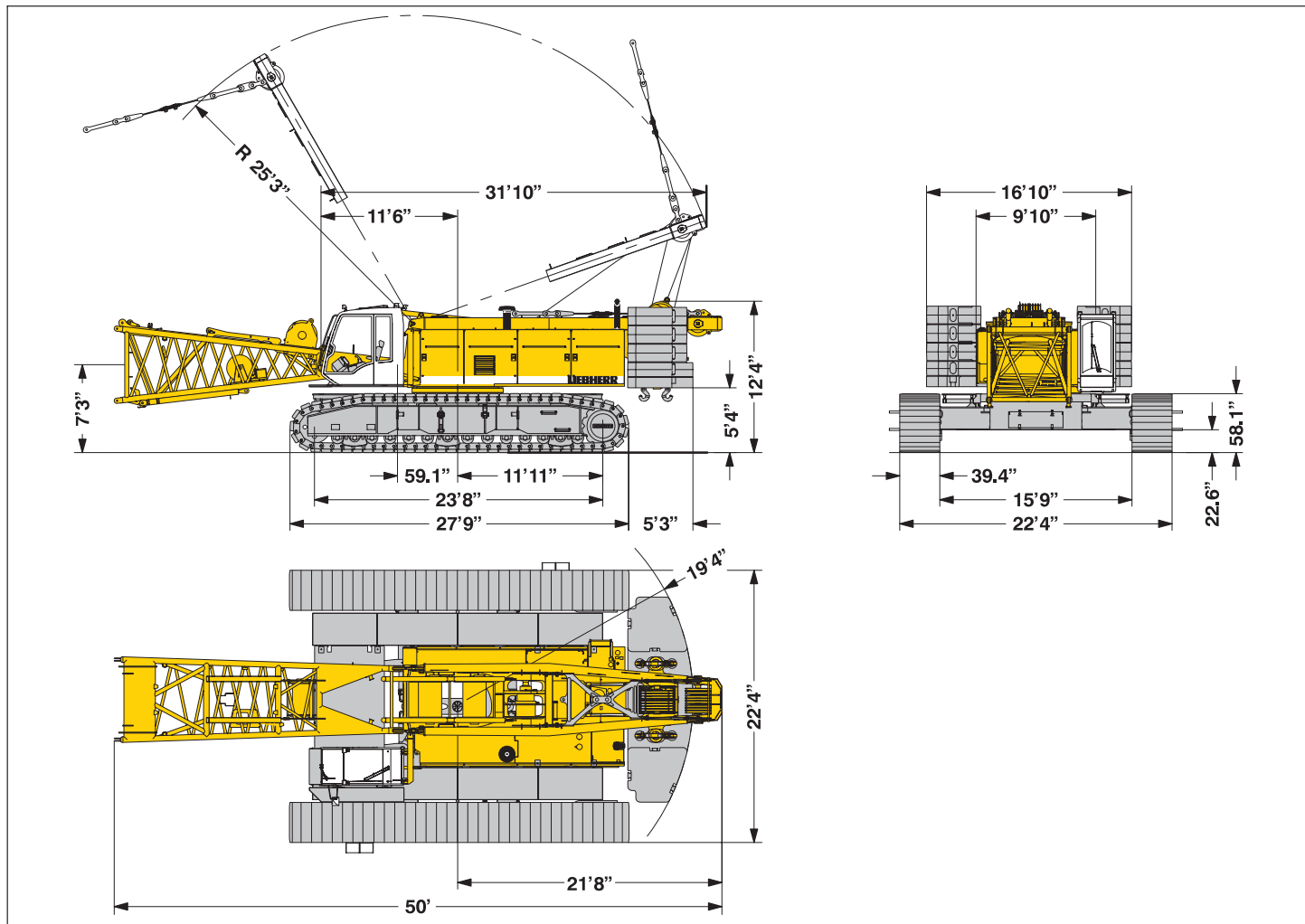

Operating weight

The operating weight includes the basic machine with crawlers, 2 main winches 26,500 lbs and 66 ft main boom, consisting of A-frame, boom foot (23 ft), boom head (23 ft), boom extension (20 ft), 133,600 lbs basic counterweight, 44,100 lbs carbody counterweight and 352,750 lbs hook block.

Total weight _____ approx. 368,200 lbs

Ground pressure

Ground bearing pressure _____ 16.5 psi

Equipment

Main boom (No. 2018.xx) max. length _____ 287 ft
 High reach (No. 2018.xx and 1309.xx) _____ 344 ft
 High reach (No. 2018.xx and 1713.xx) _____ 332 ft
 Luffing jib (No. 1309.xx) max. length _____ 258 ft
 Max. combination _____ boom 181 ft and luffing jib 258 ft
 Luffing jib (No. 1713.xx) max. length _____ 272 ft
 Max. combination _____ boom 171 ft and luffing jib 272 ft
 Fixed jib (No. 0806.xx) _____ 36 ft – 105 ft
 Fixed jib (No. 1008.xx) _____ 36 ft – 85 ft
 Auxiliary jib 53,000 lbs lifting capacity (option 79,400 lbs)

Remarks

1. The lifting capacities stated are valid for lifting operation only (corresponds with crane classification according to F.E.M. 1.001, crane group A1)
2. Crane standing on firm, horizontal ground.
3. The weight of the lifting device (hoisting ropes, hook block, shackle etc.) must be deducted from the gross lifting capacity to obtain a net lifting value.
4. Additional equipment on boom (e.g. boom walkways, auxiliary jib) must be deducted to get the net lifting capacity.
5. For max. wind speed please refer to lift chart in operator's cab or manual.
6. Working radii are measured from centre of swing and under load.
7. The lifting capacities are valid for 360 degrees of swing.
8. Calculation of stability under load is based on 75% tipping load, ANSI B 30.5 and ISO 4305 Table 2.
9. The structures are calculated according to F.E.M. 1.001 – 1998 (EN 13001-2 / 2004) and tested according to SAE J 987.

Transport dimensions and weights

Basic machine and boom (No. 2018.xx)

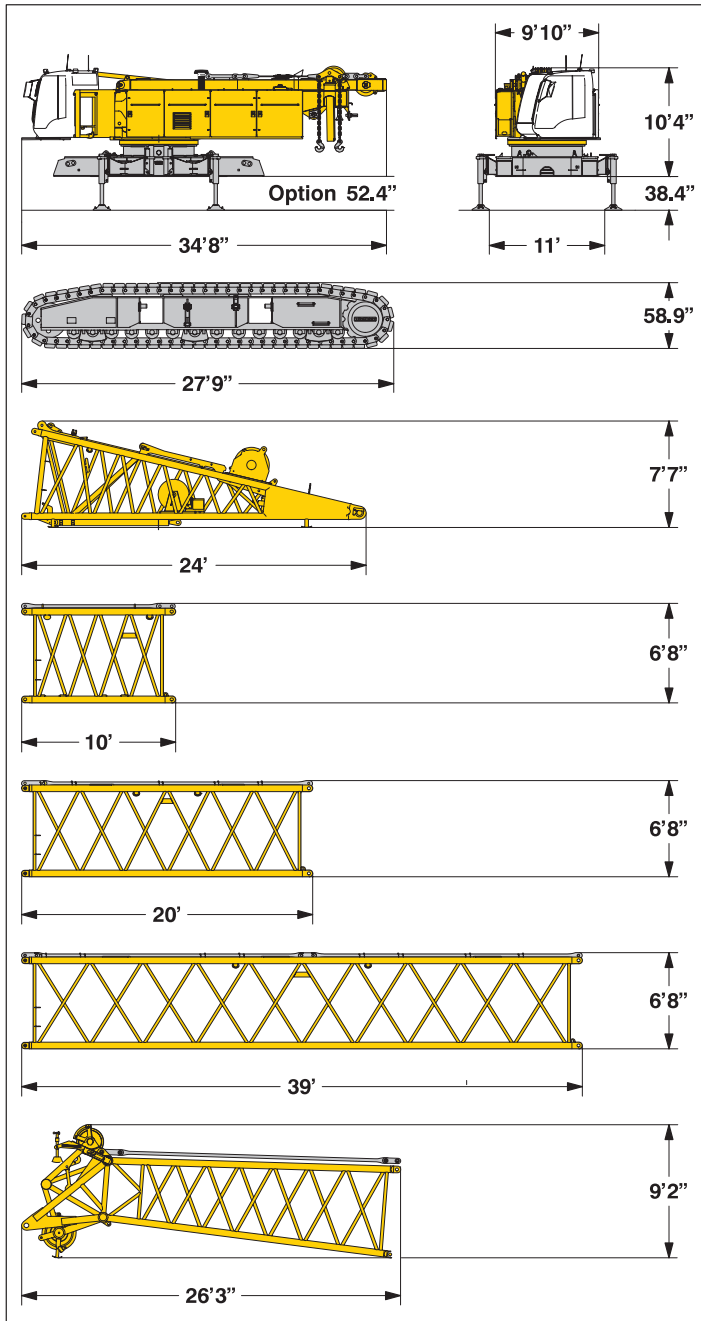

Basic machine

with A-frame, 2x 26,500 lbs crane winches without boom foot, hoisting ropes, basic counterweight and crawlers

Width	9'10"
Weight in lbs	84,900

Crawler

2x

Flat track shoes	39.4"
Width	41"
Weight in lbs	41,450

Boom foot (No. 2018.23) without winches

Width	7'11"
Weight in lbs	8,050

Boom section (No. 2018.20)

10 ft

Width	7'6"
Weight in lbs*	1,680

Boom section (No. 2018.20)

20 ft

Width	7'6"
Weight in lbs*	2,425

Boom section (No. 2018.20)

38 ft

Width	7'6"
Weight in lbs*	4,200

Boom head (No. 2018.20)

Width	7'6"
Weight in lbs*	5,960

Transport option

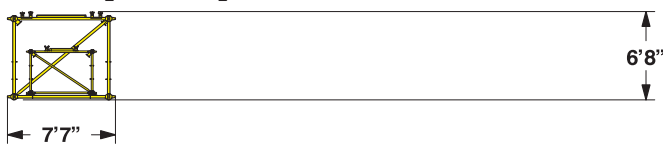

Boom - luffing jib transport option

38 ft boom – and 38 ft jib extension
20 ft boom – and 20 ft jib extension

(No. 2018.xx / 1309.xx)	20 ft/20 ft	38 ft/38 ft
Length	20'2"	38'11"
Weight in lbs*	3,850	6,970

*) Including pendants

Transport dimensions and weights

Luffing jib (No. 1309.xx)

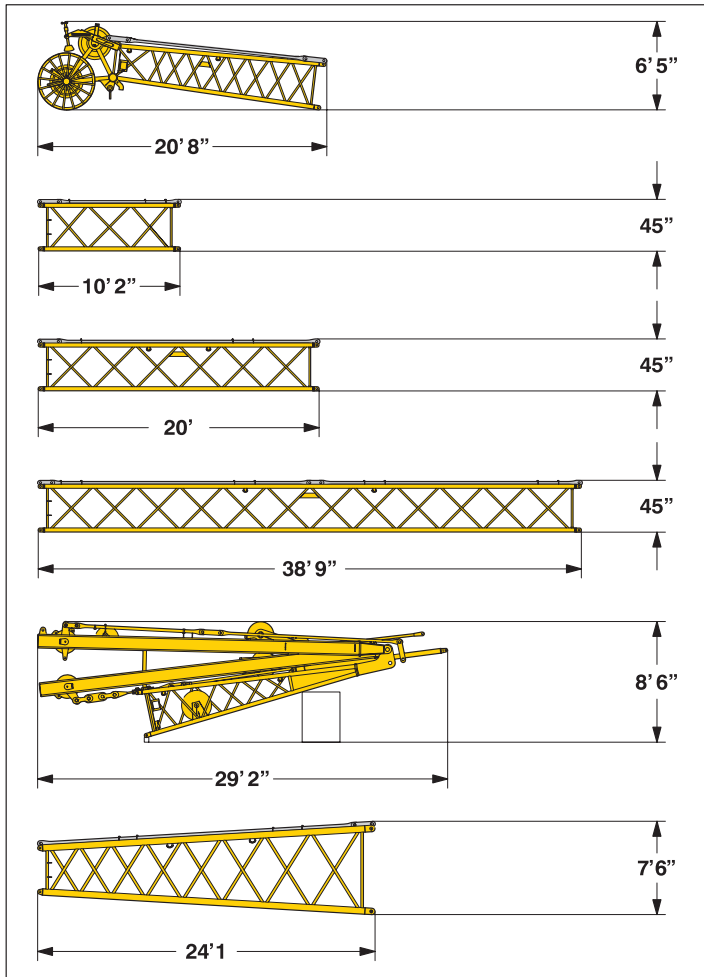

Luffing jib head (No. 1309.22)

Width	59"
Weight in lbs*	2.500

Luffing jib section (No. 1309.20) **10 ft**

Width	59"
Weight in lbs*	930

Luffing jib section (No. 1309.20) **20 ft**

Width	59"
Weight in lbs*	1.150

Luffing jib section (No. 1309.20) **38 ft**

Width	59"
Weight in lbs*	2.100

Luffing jib foot with A-frames (No. 1309.22)

Width	5'7"
Weight in lbs*	10.600

Boom section tapered (No. 2018/1309.20) **23.6 ft**

Width	7'6"
Weight in lbs*	2.700

Fixed jib (No. 0806.xx)

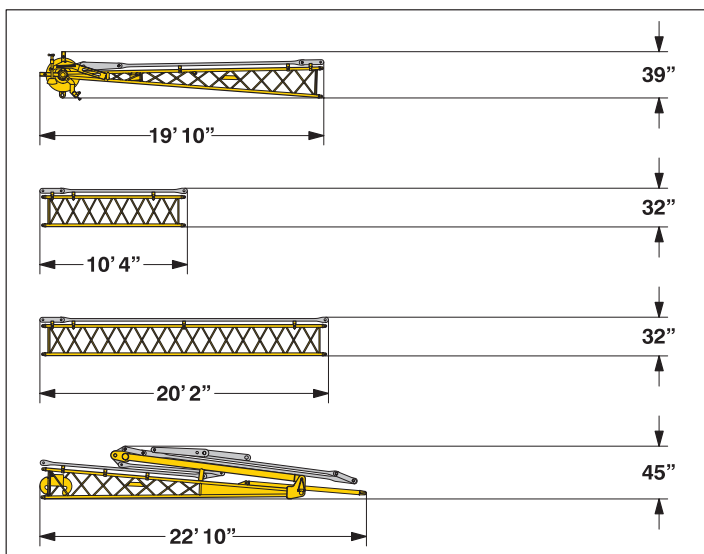

Fixed jib head (No. 0806.16)

Width	45"
Weight in lbs*	980

Fixed jib section (No. 0806.15) **10 ft**

Width	38"
Weight in lbs*	245

Fixed jib section (No. 0806.15) **20 ft**

Width	38"
Weight in lbs*	430

Fixed jib foot with A-frame (No. 0806.16)

Width	59"
Weight in lbs*	2.050

*) Including pendants

Transport dimensions and weights

Luffing jib (No. 1713.xx)

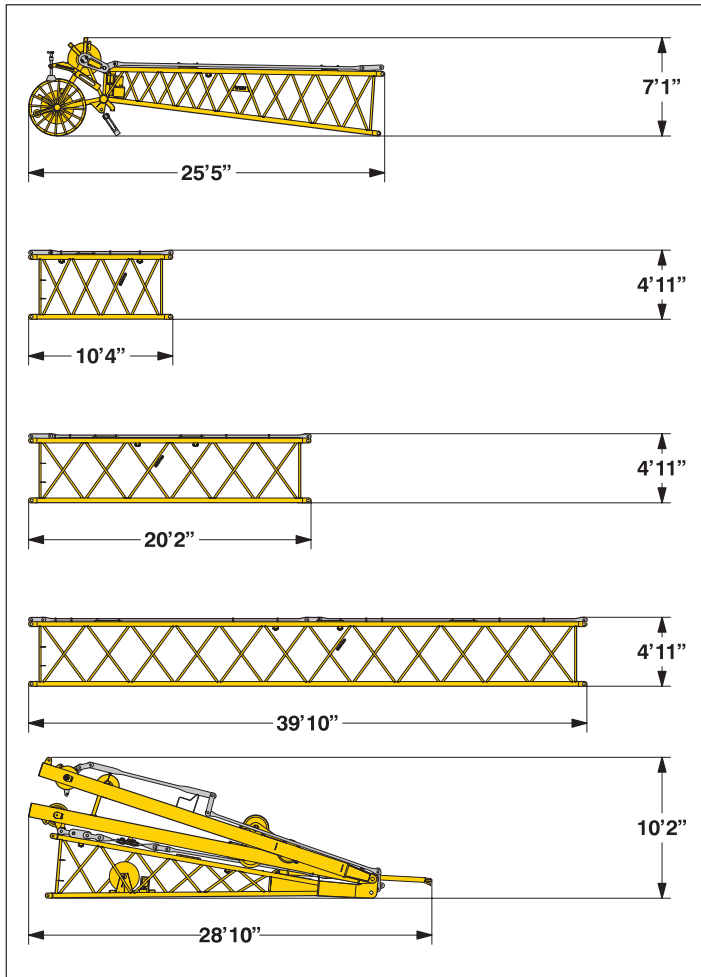

Luffing jib head (No. 1713.21)

Width	59"
Weight in lbs*	2.500

Luffing jib section (No. 1713.18) 10 ft

Width	59"
Weight in lbs*	930

Luffing jib section (No. 1713.18) 20 ft

Width	59"
Weight in lbs*	1.150

Luffing jib section (No. 1713.18) 40 ft

Width	59"
Weight in lbs*	2.120

Luffing jib foot with A-frames (No. 1713.22)

Width	5'7"
Weight in lbs*	10.600

Fixed jib (No. 1008.xx)

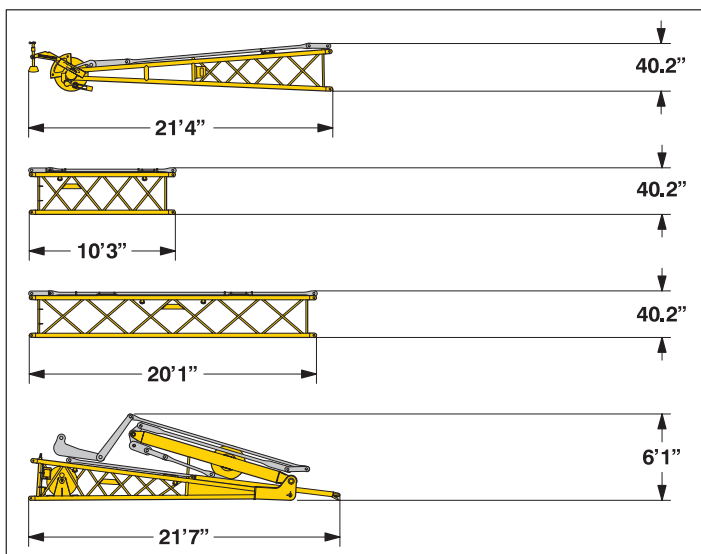

Fixed jib head (No. 1008.20)

Width	45"
Weight in lbs*	2.060

Fixed jib section (No. 1008.17) 10 ft

Width	43"
Weight in lbs*	660

Fixed jib section (No. 1008.17) 20 ft

Width	43"
Weight in lbs*	1.010

Fixed jib foot with A-frame (No. 1008.20)

Width	59"
Weight in lbs*	4.300

*) Including pendants

Transport dimensions and weights

Counterweight

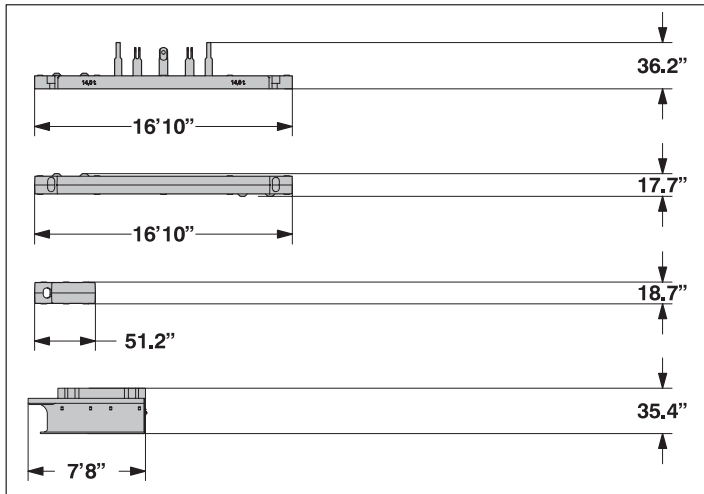

Counterweight **1x**

Width	5'5"
Weight in lbs	32,000

Counterweight **1x**

Width	5'5"
Weight in lbs	35,940

Counterweight **6x**

Width	53.5"
Weight in lbs	11,245

Carbody counterweight **2x**

Width	9'11"
Weight in lbs	22,050

Mid fall (option)

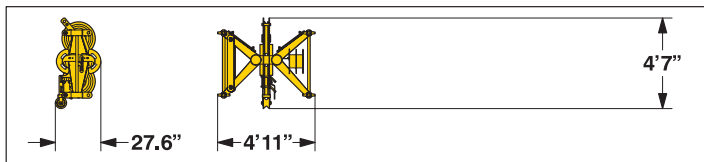

Mid fall section (No. 1309.32) **1.1 ft**

Width	27.6"
Weight in lbs	600

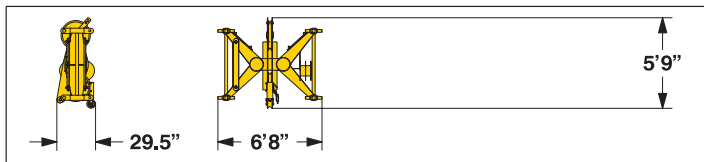

Mid fall section (No. 1713.31) **1.6 ft**

Width	27.6"
Weight in lbs	850

Hooks

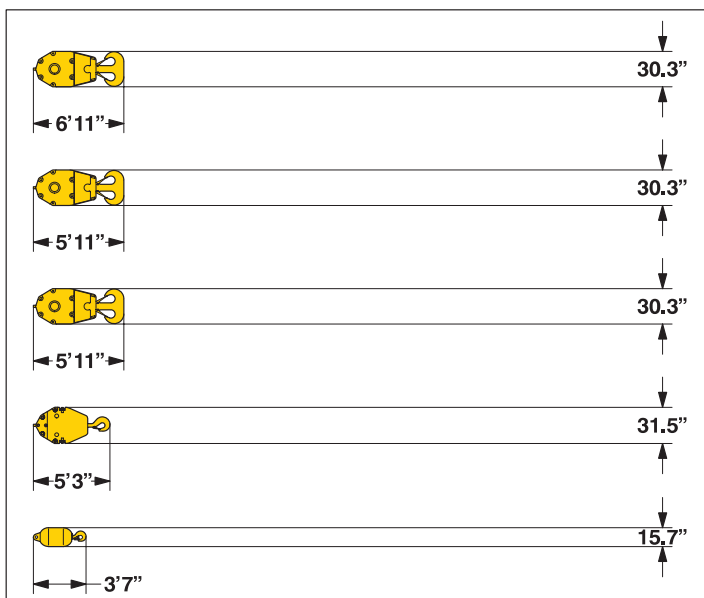

352,750 lbs hook block - 7 sheaves

Width	25.2" — 30" — 34.6"
Weight in lbs	3,310 — 4,690 — 6,615

220,500 lbs hook block - 5 sheaves

Width	21.3" — 26.4" — 30.3"
Weight in lbs	2,870 — 3,970 — 5070

176,400 lbs hook block - 3 sheaves

Width	14.2" — 18.1" — 22"
Weight in lbs	2,200 — 3,310 — 4,410

88,200 lbs hook block - 1 sheave

Width	11.8" — 15.8" — 19.7"
Weight in lbs	1,550 — 2,425 — 3,310

27,600 lbs single hook

Width	15.8"
Weight in lbs	1,330

Technical description



Engine

Power rating according to ISO 9249, 270 kW (362 hp) at 2000 rpm
Engine type _____ Liebherr D 936 L A6
Fuel tank _____ 790 l capacity with continuous level indicator
and reserve warning

Engine complies with NRMM exhaust certification EPA / CARB Tier 3 and 97/68 EC Stage III



Hydraulic system

A double axial displacement pump supplies the open loop hydraulic system, allowing all functions to be operated simultaneously. To minimize peak pressure an automatic working pressure cut-off is integrated in the pump. All filters are electronically monitored.

The use of synthetic environmentally friendly (biodegradable) oils is possible.

Working pressure _____ max. 5076 PSI

Oil tank capacity _____ 172 gal



Luffing jib winch

Line pull _____ max. 23,150 lbs

Rope diameter _____ 20 mm

Jib luffing _____ 46 sec. from 15° to 78°



Boom winch

Line pull _____ max. 47,850 lbs

Rope diameter _____ 24 mm

Boom up _____ 119 sec. from 15° to 86°



Swing

Consists of rollerbearing with external teeth, swing drive with fixed axial piston hydraulic motor, spring loaded and hydraulically released multi-disc holding brake, planetary gearbox and pinion.

Both swing modes are possible – speed control or free swing.

A multi-disc holding brake acts automatically at zero swing motion.

Swing speed from 0 – 3 rpm continuously variable.



Main winches

Line pull (1st layer) _____ max. 38,600 lbs

Line pull (7th layer) _____ 26,500 lbs

Rope diameter _____ 26 mm

Drum diameter _____ 23 inch

Rope speed ft/min _____ 0 – 446

Rope capacity in 7 layers _____ 1600 ft

The winches are outstanding in their compact design and easy assembly. Propulsion is via a planetary gearbox in an oil bath.

Load support by the hydraulic system; additional safety factor provided by a spring loaded, multi-disc holding brake.

The main winches use pressure controlled, variable flow hydraulic motors. This system features sensors that automatically adjust oil flow to provide max. winch speed depending on load.

Option – winch with freefall system:

Clutch and braking functions on the freefall system are provided by a compact designed, low wear and maintenance free multi-disc brake.



Crawlers

Propulsion through axial piston motor, hydraulically released spring loaded multi-disc brake, crawler tracks, hydraulic chain tensioning device.

Flat track shoes _____ 39.4 inch

Drive speed _____ 0 – 0.9 mph



Control

The control system – developed and manufactured by Liebherr – is designed to withstand extreme environmental conditions such as temperature, vibration and electromagnetic interference and to meet all requirements that are needed in heavy duty crane operation.

Complete machine operating data are shown on a high resolution display. Standard operational information is displayed by means of graphical symbols, fault indications are displayed in plain text (more than 15 languages available).

The cranes are equipped with proportional control for all main movements, which can be carried out simultaneously.

The crane is operated with 2 multi-directional joysticks, the right for winch I and boom, the left for winch II and swing control.

Option:

Bi-directional double T-levers for simultaneous boom and luffing jib operation.

The crawlers are activated by the two central foot pedals. Additionally, hand levers can be attached to the pedals.

Remote control for assembly of counterweight and boom hinge pins.



Noise emission

Noise emissions correspond with 2000/14/EC directive on noise emission by equipment used outdoors.

Boom combinations

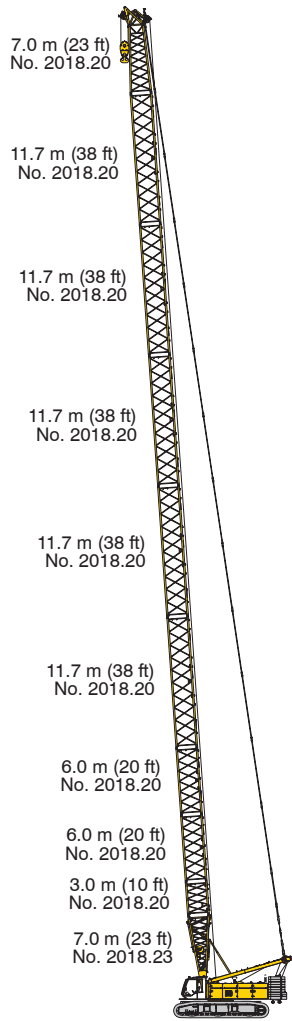

Main boom No. 2018.xx — 287 ft

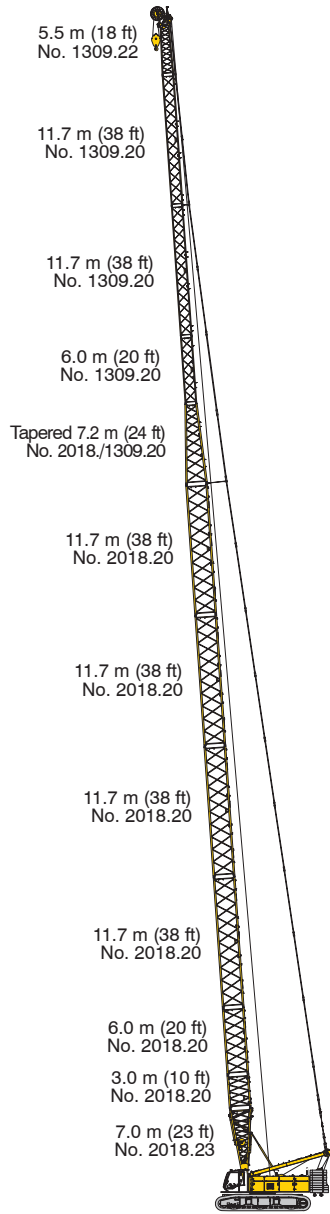

Max. combination — 344 ft
 Main boom No. 2018.xx — 206 ft
 Tapered No. 2018/1309.xx — 24 ft
 Luffing jib No. 1309.xx — 114 ft

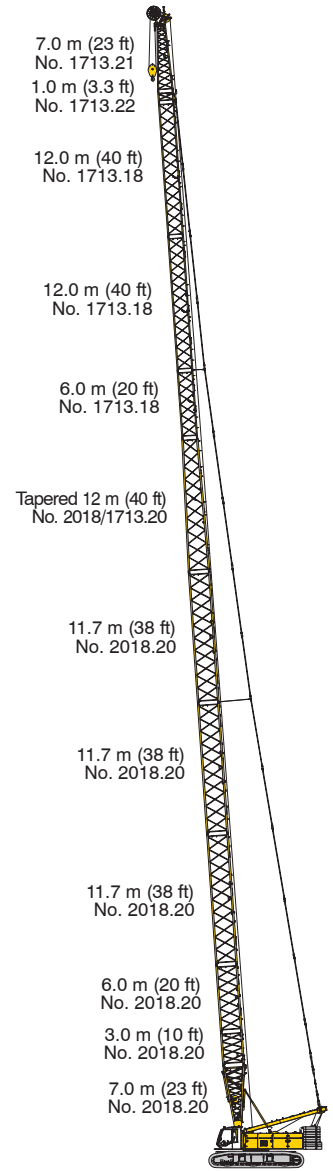

Max. combination — 332 ft
 Main boom No. 2018.xx — 168 ft
 Tapered No. 2018/1713.xx — 39 ft
 Luffing jib No. 1713.xx — 125 ft

Boom combinations

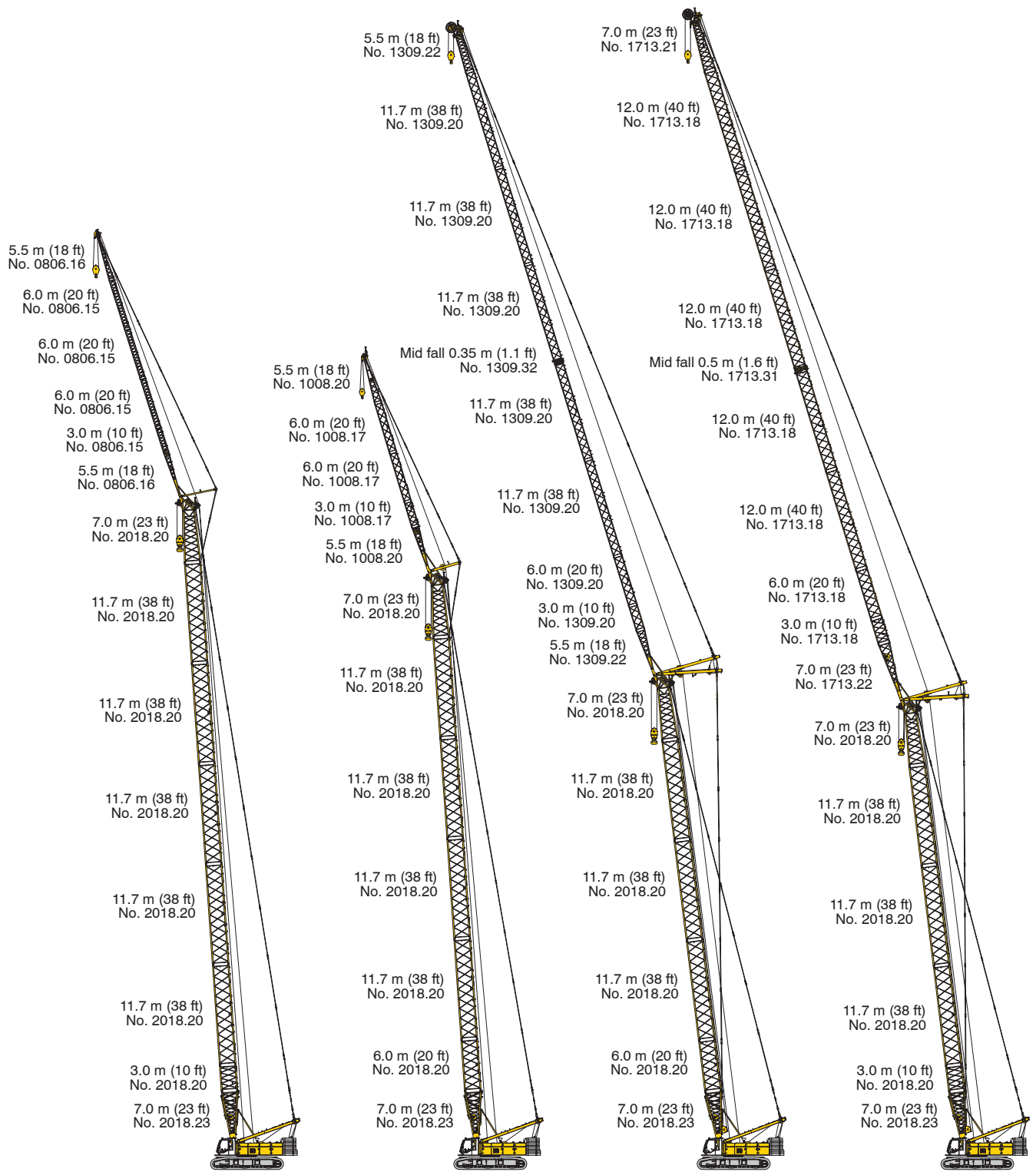

Max. combination — 353 ft
 Main boom No. 2018.xx — 248 ft
 Fixed jib No. 0806.xx — 105 ft
 Main boom No. 2018.xx — 258 ft
 Fixed jib No. 0806.xx — 85 ft

Max. combination — 304 ft
 Main boom No. 2018.xx — 219 ft
 Luffing jib No. 1008.xx — 85 ft
 Main boom No. 2018.xx — 229 ft
 Luffing jib No. 1008.xx — 66 ft

Max. combination — 439 ft
 Main boom No. 2018.xx — 181 ft
 Luffing jib No. 1309.xx — 258 ft
 Main boom No. 2018.xx — 191 ft
 Luffing jib No. 1309.xx — 219 ft

Max. combination — 443 ft
 Main boom No. 2018.xx — 171 ft
 Luffing jib No. 1713.xx — 272 ft
 Main boom No. 2018.xx — 191 ft
 Luffing jib No. 1713.xx — 164 ft

Self assembly system

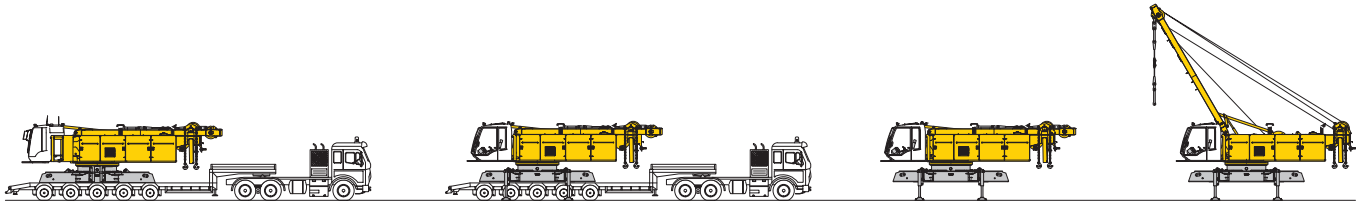

Unloading of basic machine

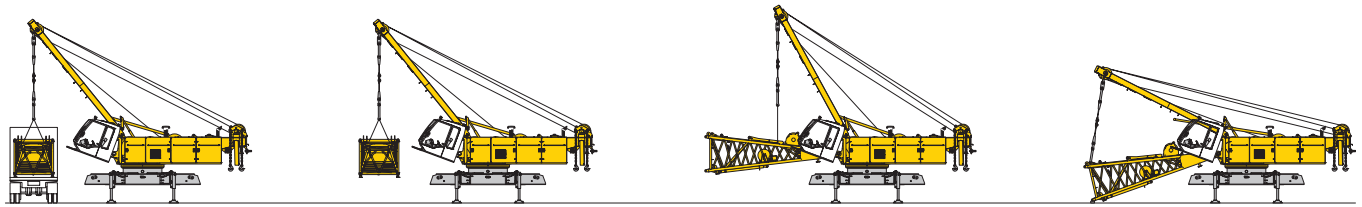

Unloading and assembly of boom foot

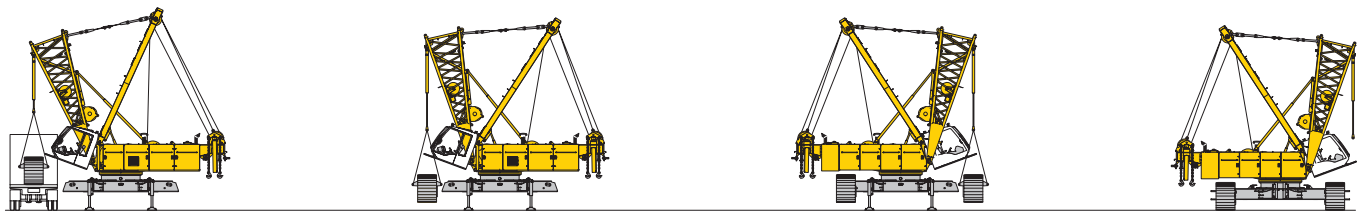

Unloading and assembly of crawlers

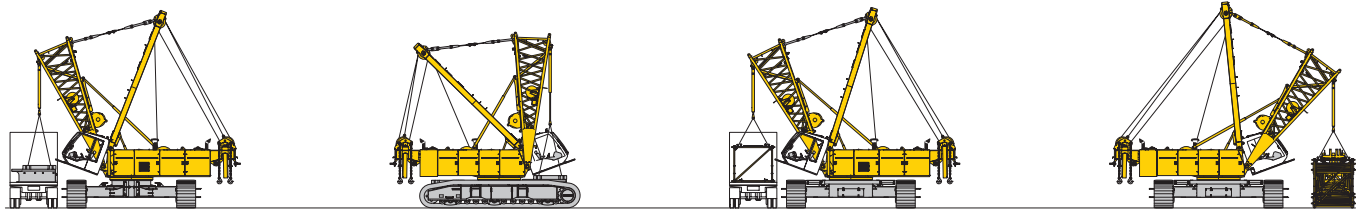

Unloading and assembly of carbody counterweight

Unloading and assembly of boom

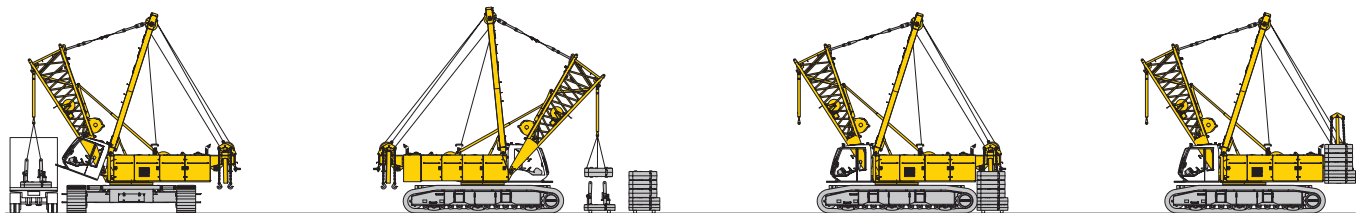

Unloading and assembly of counterweight

Erecting of main boom to working position

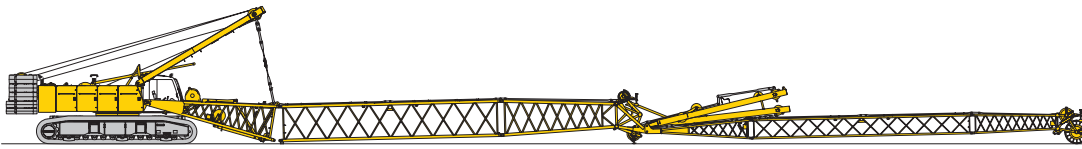

Assembly of boom

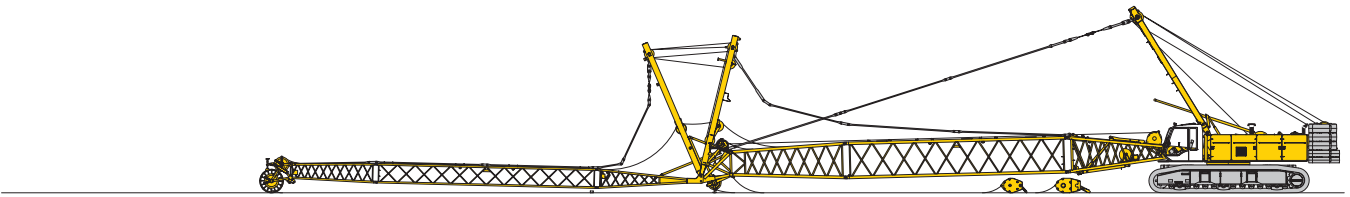

Reeving of hoist and luffing jib ropes

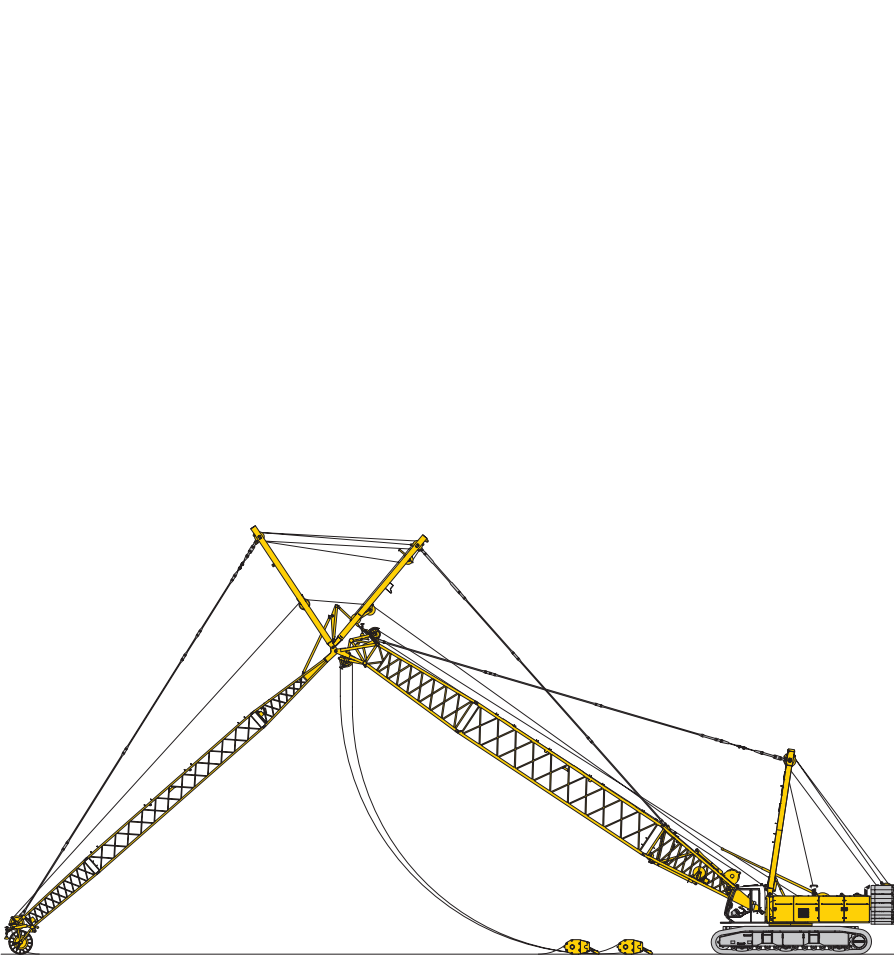

Erecting of main boom and luffing jib

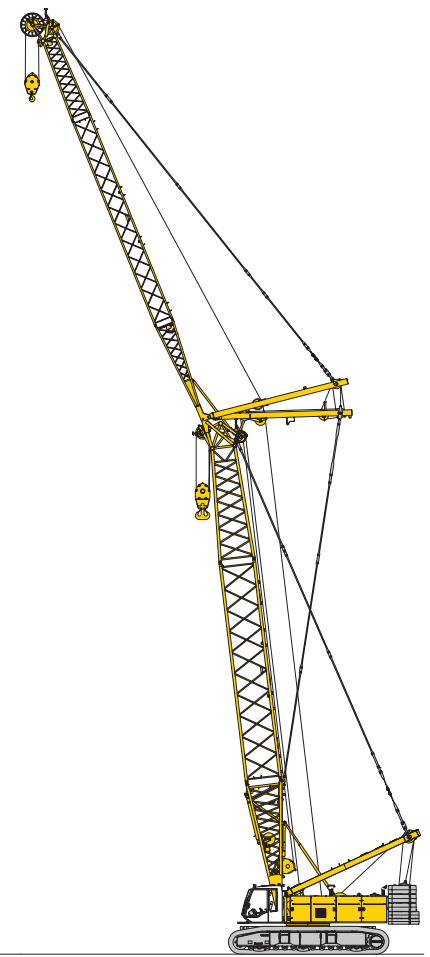

Working position

Working range - main boom (No. 2018.xx) **86° - 15°** **121,300 lbs counterweight and 33,100 lbs carbody counterweight**

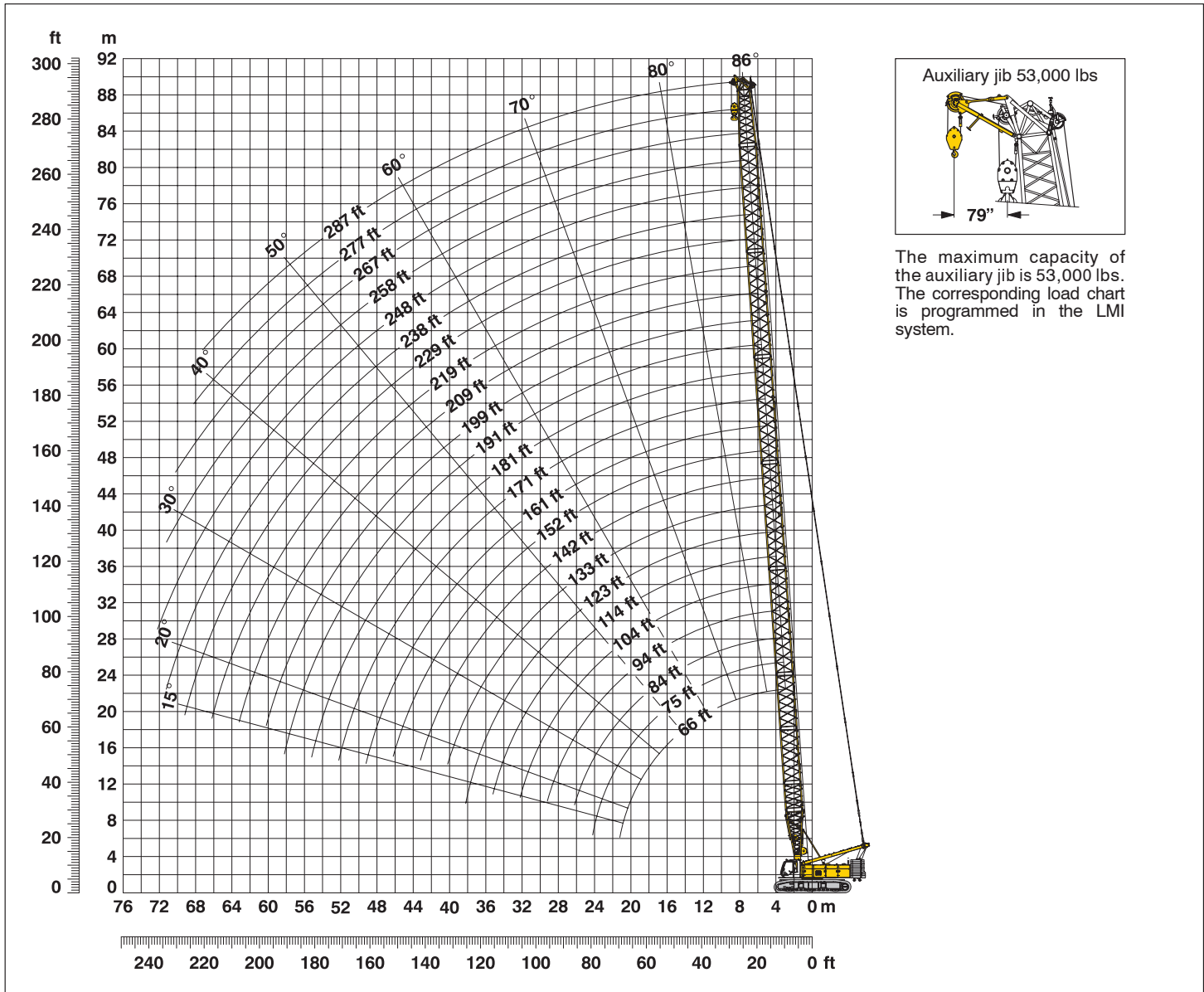

Main boom configuration (Table1 – No. 2018.xx)

Configuration for boom lengths between 66 ft – 287 ft:

Length	Amount of boom extensions																							
	1	1	1	1	1	1	1	1	1	1	1	1	1	1	1	1	1	1	1	1				
Boom foot 23 ft	1	1	1	1	1	1	1	1	1	1	1	1	1	1	1	1	1	1	1	1				
Boom insert 10 ft*		1		1		1		1		1		1		1		1		1		1				
Boom insert 20 ft*	1	1		1	1	1		1	1		1	1		1	1		1	1		1				
Boom insert 38 ft*			1	1	1	1	2	2	2	3	3	3	3	4	4	4	4	5	5	5	5			
Boom head 23 ft	1	1	1	1	1	1	1	1	1	1	1	1	1	1	1	1	1	1	1	1	1			
Boom length (ft)	66	75	84	94	104	114	123	133	142	152	161	171	181	191	199	209	219	229	238	248	258	267	277	287

*Actual lengths of boom sections are metric (e.g. 3 m, 6 m, 11.7 m). The figures shown above are approximate conversions to feet.

Lift chart for main boom (No. 2018.xx)

Capacities in 1000 lbs for boom lengths (66 ft – 287 ft) – with 26,500 kN winches
133,600 lbs counterweight and 44,100 lbs carbody counterweight

Radius	Boom length in (ft)											
	66	94	114	133	152	171	191	209	229	248	267	287
(ft)	lbs	lbs	lbs	lbs	lbs	lbs	lbs	lbs	lbs	lbs	lbs	lbs
12.2	400,0*											
15	308.7	302.5										
20	302.1	294.1	278.0	245.0	205.0							
25	259.4	256.4	235.7	233.5	196.5	166.7	138.8	110.4	91.5			
30	198.3	191.7	198.5	187.8	172.1	161.0	134.0	107.1	90.0	75.6	63.2	53.1
40	130.3	129.5	130.1	125.3	125.1	129.2	119.3	96.4	85.0	73.1	60.9	50.5
50	96.0	96.0	95.7	95.4	95.0	94.6	94.2	87.6	80.4	70.2	58.3	48.0
60	75.3	75.3	75.0	74.7	74.2	73.8	73.3	72.9	72.2	66.3	55.6	45.5
65	67.7	67.8	67.5	67.2	66.7	66.3	65.7	65.3	64.8	63.7	54.1	44.4
80		51.4	51.1	50.8	50.3	49.9	49.4	48.9	48.3	47.8	47.3	41.3
95		40.7	40.6	40.3	39.8	39.4	38.8	38.3	37.7	37.2	36.6	36.0
100			37.8	37.6	37.1	36.6	36.1	35.6	35.0	34.5	33.8	33.2
110			33.1	32.9	32.4	32.0	31.4	30.9	30.3	29.8	29.1	28.5
120				29.0	28.6	28.1	27.6	27.1	26.6	26.1	25.5	24.9
130				26.0	25.5	25.1	24.5	24.0	23.4	22.9	22.3	21.6
140					22.8	22.4	21.8	21.3	20.7	20.2	19.5	18.9
150					20.4	20.1	19.5	19.0	18.4	17.8	17.2	16.5
160						18.0	17.5	17.0	16.3	15.8	15.2	14.5
170							16.2	15.7	15.2	14.6	14.0	13.4
180								14.1	13.6	13.0	12.5	11.8
190								12.6	12.2	11.6	11.0	10.4
200									10.9	10.3	9.8	9.1
205									10.3	9.7	9.2	8.6
210										9.2	8.6	8.0
220										8.1	7.6	7.0
225										7.6	7.1	6.5
230											6.7	6.0
240											5.8	5.2
245											5.3	4.8
250												4.4
260												3.6
270												2.3

Above lift chart is for reference only. For actual lift duty please refer to lift chart in operator's cab or manual.

* Capacities over 308,700 lbs require a special heavy duty boom head.

L - boom high reach (No.2018 / 1309.xx) **219 ft - 344 ft**

Working range **84° - 15°**

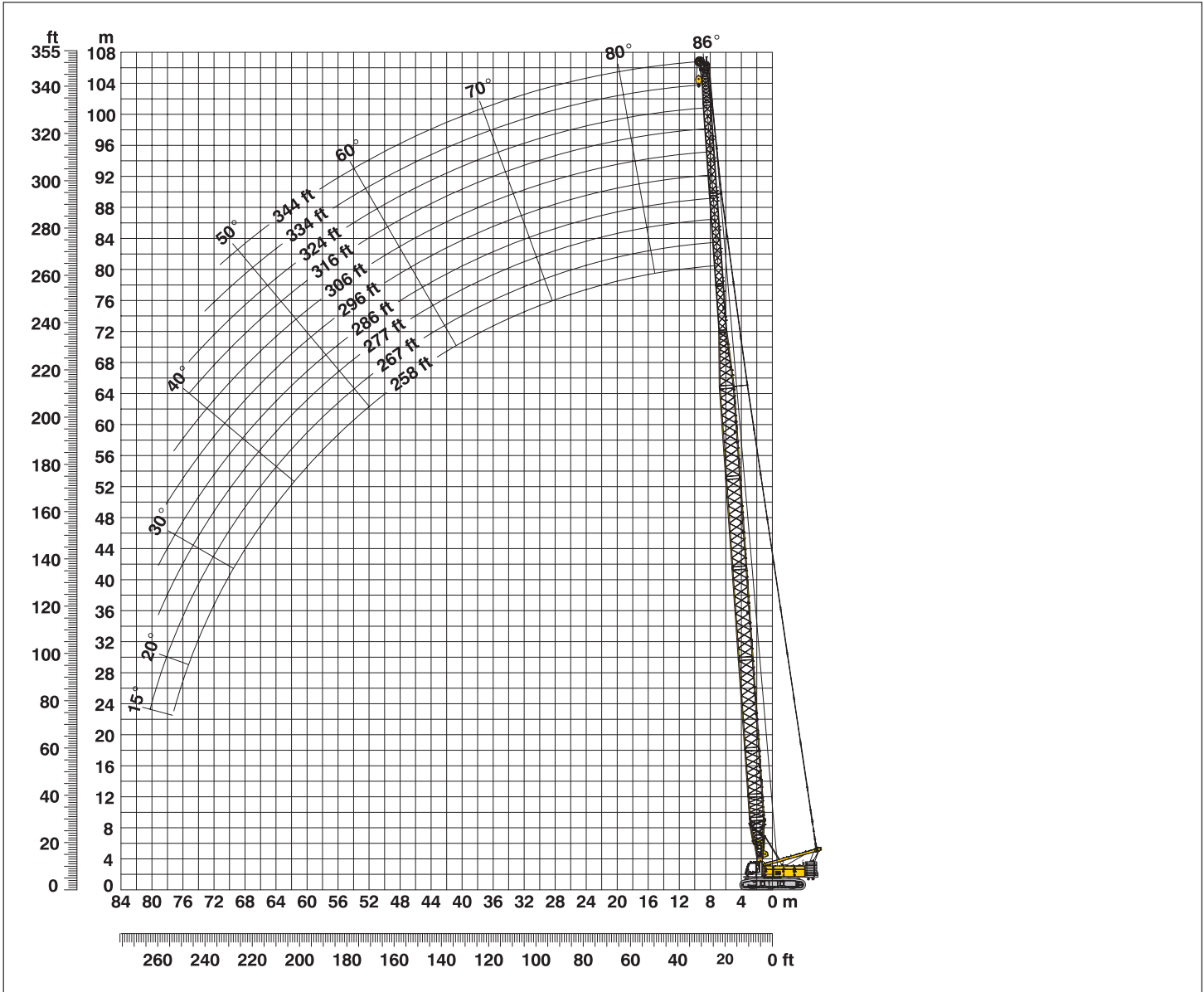

L - boom configuration with 168 ft main boom (No. 2018.xx / No. 1309.xx)

Configuration for L - boom lengths (219 ft – 316 ft)

Component	Length	Amount of boom and luffing jib extensions										
		1	2	3	4	5	6	7	8	9	10	11
Boom foot	23 ft	1	1	1	1	1	1	1	1	1	1	1
Boom insert	10 ft*	1	1	1	1	1	1	1	1	1	1	1
Boom insert	20 ft*	1	1	1	1	1	1	1	1	1	1	1
Boom insert	38 ft*	3	3	3	3	3	3	3	3	3	3	3
Tapered	24 ft*	1	1	1	1	1	1	1	1	1	1	1
Luffing insert	10 ft*	1		1		1		1		1		1
Luffing insert	20 ft*		1	1		1		1		1		1
Luffing insert	38 ft*				1	1	1	1	2	2	2	2
Luffing jib head	18 ft	1	1	1	1	1	1	1	1	1	1	1
Max. L - boom length (ft)		219	229	239	248	258	267	277	286	296	306	316

*Actual lengths of boom sections are metric (e.g. 3 m, 6 m, 7.2 m, 11.7 m). The figures shown above are approximate conversions to feet.

Lift chart for L – boom (No. 2018 /1309.xx)

Main boom length 168 ft

Capacities in 1000 lbs
133,600 lbs counterweight and 44,100 lbs carbody counterweight

Radius (ft)	Boom length in (ft)				
	219	258	277	296	316
22	99.5				
25	99.3	59.0			
30	97.4	57.8	43.6	33.8	22.9
40	93.6	52.3	39.2	30.9	21.0
50	80.3	47.6	35.4	27.8	19.1
60	65.4	43.6	32.1	24.3	17.4
70	53.9	40.1	29.2	22.2	16.0
80	48.2	37.0	27.0	20.4	14.7
90	42.6	34.2	24.6	18.9	13.7
100	37.4	31.5	22.7	17.4	12.7
110	32.8	29.0	20.7	16.0	11.7
120	29.0	27.1	19.2	14.6	10.7
130	25.3	25.2	18.2	13.6	9.7
140	23.2	23.0	17.1	12.8	9.3
150	20.9	20.7	16.2	12.0	8.9
160	18.8	18.7	15.5	11.4	8.4
170	17.1	16.9	14.7	10.8	8.0
180	15.5	15.3	13.9	10.3	7.6
190	14.1	13.9	13.0	9.7	7.3
200	12.9	12.7	12.0	9.3	6.9
210	11.7	11.6	11.0	8.9	6.6
215	11.2	11.0	10.4	8.7	6.5
230		9.1	9.0	8.0	6.2
250		7.3	6.9	6.6	5.6
260			6.2	5.8	5.0
270			5.3	5.1	4.4
280				4.4	3.7
290				3.6	3.2
300					2.6
305					2.3

Main boom length 206 ft

Capacities in 1000 lbs
133,600 lbs counterweight and 44,100 lbs carbody counterweight

Radius (ft)	Boom length in (ft)				
	258	277	296	316	344
24.7	70.0				
30	69.4	58.2	47.1	36.1	
35	68.3	57.3	45.9	35.5	23.7
40	67.1	56.4	44.3	34.0	23.1
50	64.3	53.7	41.2	31.1	21.6
60	57.7	50.3	38.4	28.5	20.4
70	49.5	47.5	35.9	25.2	19.2
80	43.2	42.0	33.7	23.8	18.0
90	38.6	36.7	31.6	22.3	17.0
100	34.6	33.3	29.6	20.8	16.1
110	30.9	29.9	27.7	19.4	15.2
120	27.7	26.9	25.3	18.1	14.3
130	23.8	23.7	23.7	16.7	13.4
140	22.0	21.7	21.5	15.9	12.5
150	19.7	19.6	19.3	15.2	12.0
160	17.7	17.5	17.3	14.5	11.5
170	15.9	15.8	15.6	13.6	11.1
180	14.3	13.9	13.9	12.5	10.6
190	12.9	12.6	12.1	11.4	9.8
200	11.3	11.3	10.9	10.3	8.9
210	10.3	9.9	9.8	9.2	8.0
220	9.2	8.7	8.5	8.2	7.1
230	7.9	7.8	7.3	7.2	6.2
240	7.0	6.8	6.5	6.0	5.3
250	6.0	5.7	5.7	5.2	4.4
260		4.9	4.7	4.4	3.4
270		3.8	3.9	3.6	2.8
285			2.8	2.5	2.2
290			2.3	2.3	
295				2.0	

Above lift chart is for reference only. For actual lift duty please refer to lift chart in operator's cab or manual.

L – boom configuration with 206 ft main boom (No. 2018.xx / No. 1309.xx)

Configuration for L – boom lengths (258 ft – 344 ft)

	Length	Amount of boom and luffing jib extensions									
		258	267	277	286	296	306	316	324	334	344
Boom foot	23 ft	1	1	1	1	1	1	1	1	1	1
Boom insert	10 ft*	1	1	1	1	1	1	1	1	1	1
Boom insert	20 ft*	1	1	1	1	1	1	1	1	1	1
Boom insert	38 ft*	4	4	4	4	4	4	4	4	4	4
Tapered	24 ft*	1	1	1	1	1	1	1	1	1	1
Luffing insert	10 ft*	1		1		1		1		1	
Luffing insert	20 ft*		1	1			1	1			1
Luffing insert	38 ft*				1	1	1	1	2	2	2
Luffing jib head	18 ft	1	1	1	1	1	1	1	1	1	1
Max. L – boom length (ft)		258	267	277	286	296	306	316	324	334	344

*Actual lengths of boom sections are metric (e.g. 3 m, 6 m, 7.2 m, 11.7 m). The figures shown above are approximate conversions to feet.

L - boom high reach (No.2018 / 1713.xx) **243 ft - 332 ft** Working range 84° - 15°

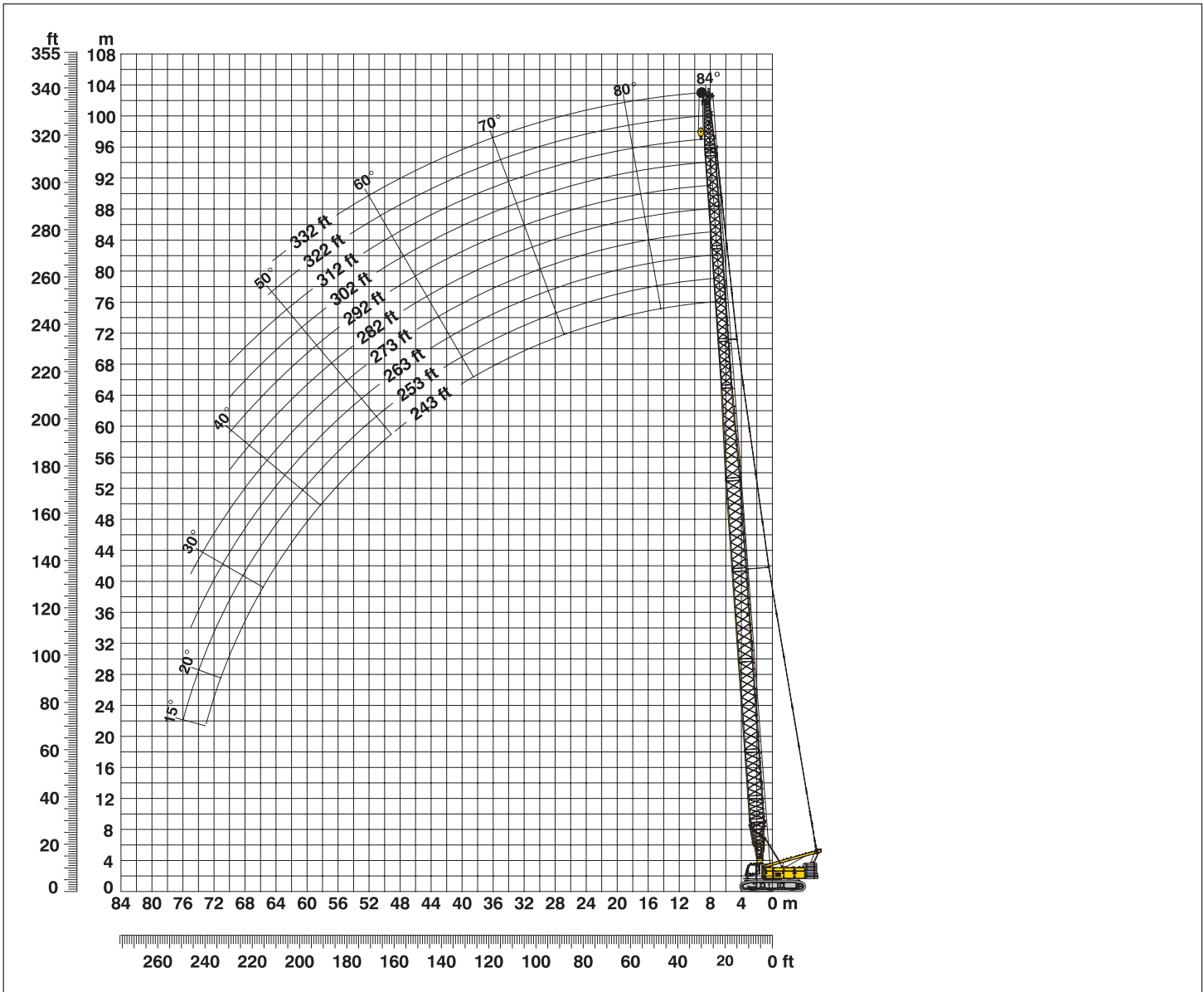

L - boom configuration with 206 ft main boom (No. 2018.xx / No. 1309.xx)

Configuration for L - boom lengths (258 ft - 344 ft)

Configuration	Length	Amount of boom and luffing jib extensions									
		1	1	1	1	1	1	1	1	1	1
Boom foot	23 ft	1	1	1	1	1	1	1	1	1	1
Boom insert	10 ft*	1	1	1	1	1	1	1	1	1	1
Boom insert	20 ft*	1	1	1	1	1	1	1	1	1	1
Boom insert	38 ft*	4	4	4	4	4	4	4	4	4	4
Tapered	24 ft*	1	1	1	1	1	1	1	1	1	1
Luffing insert	10 ft*	1		1		1		1		1	
Luffing insert	20 ft*		1	1			1	1			1
Luffing insert	38 ft*				1	1	1	1	2	2	2
Luffing jib head	18 ft	1	1	1	1	1	1	1	1	1	1
Max. L - boom length (ft)		258	267	277	286	296	306	316	324	334	344

*Actual lengths of boom sections are metric (e.g. 3 m, 6 m, 7.2 m, 11.7 m). The figures shown above are approximate conversions to feet.

Lift chart for L – boom (No. 2018 /1309.xx)

Capacities in 1000 lbs for boom lengths (243 ft – 332 ft) – with 26,500 kN winches
133,600 lbs counterweight and 44,100 lbs carbody counterweight

Radius (ft)	Boom length in (ft)										Radius (ft)	
	243	253	263	273	282	292	302	312	322	332		
23.7	81.5											23.7
25	81.5	73.5										25
30	80.8	72.9	66.6	60.8	53.0	49.8	45.4	40.7	36.9			30
35	79.8	71.9	65.9	59.9	53.0	49.0	44.5	40.2	36.6	32.9		35
40	78.0	70.9	65.3	59.0	53.0	47.8	43.5	39.3	35.9	32.2		40
60	62.6	59.4	57.5	53.9	47.8	43.2	39.5	35.6	32.5	29.3		60
80	45.0	43.9	43.7	43.6	40.6	37.7	34.9	31.4	28.4	23.9		80
100	35.9	34.2	34.5	33.9	32.9	32.0	30.9	28.2	24.7	21.7		100
120	27.9	27.6	27.6	27.4	26.0	26.5	25.0	24.2	22.4	20.0		120
140	22.1	22.1	21.8	21.8	21.6	21.5	21.2	20.7	19.5	18.2		140
160	17.8	17.7	17.4	17.5	17.2	17.0	16.4	16.3	15.7	15.0		160
170	16.0	15.9	15.7	15.7	15.5	15.3	14.8	14.5	13.9	13.4		170
180	14.4	14.4	14.1	14.2	13.7	13.5	13.1	12.9	12.5	12.0		180
190	13.0	13.0	12.7	12.8	12.2	11.7	11.4	11.3	11.0	10.7		190
200	11.8	11.6	11.3	11.4	11.0	10.6	10.0	9.7	9.5	9.3		200
210	10.7	10.5	10.0	9.9	9.6	9.4	8.9	8.6	8.1	7.9		210
220	9.2	9.3	8.9	8.9	8.3	8.1	7.7	7.6	7.2	6.8		220
230	8.2	8.0	7.8	7.9	7.4	7.0	6.6	6.6	6.2	5.9		230
235	7.7	7.6	7.1	7.4	7.0	6.6	6.0	6.0	5.7	5.5		235
245		6.6	6.3	6.2	6.0	5.7	5.3	5.1	4.7	4.5		245
255			5.3	5.5	4.9	4.8	4.5	4.4	3.9	3.5		255
265				4.6	4.3	3.9	3.6	3.6	3.2	3.0		265
275					3.4	3.3	2.8	2.8	2.5	2.4		275
280						2.9	2.5	2.4	2.1	2.2		280
285						2.5	2.2	2.2				285
290								2.0				290

Above lift chart is for reference only. For actual lift duty please refer to lift chart in operator's cab or manual.

Working range - luffing jib (No. 1309.xx) 78° - 15°

Main boom 88° - 45°

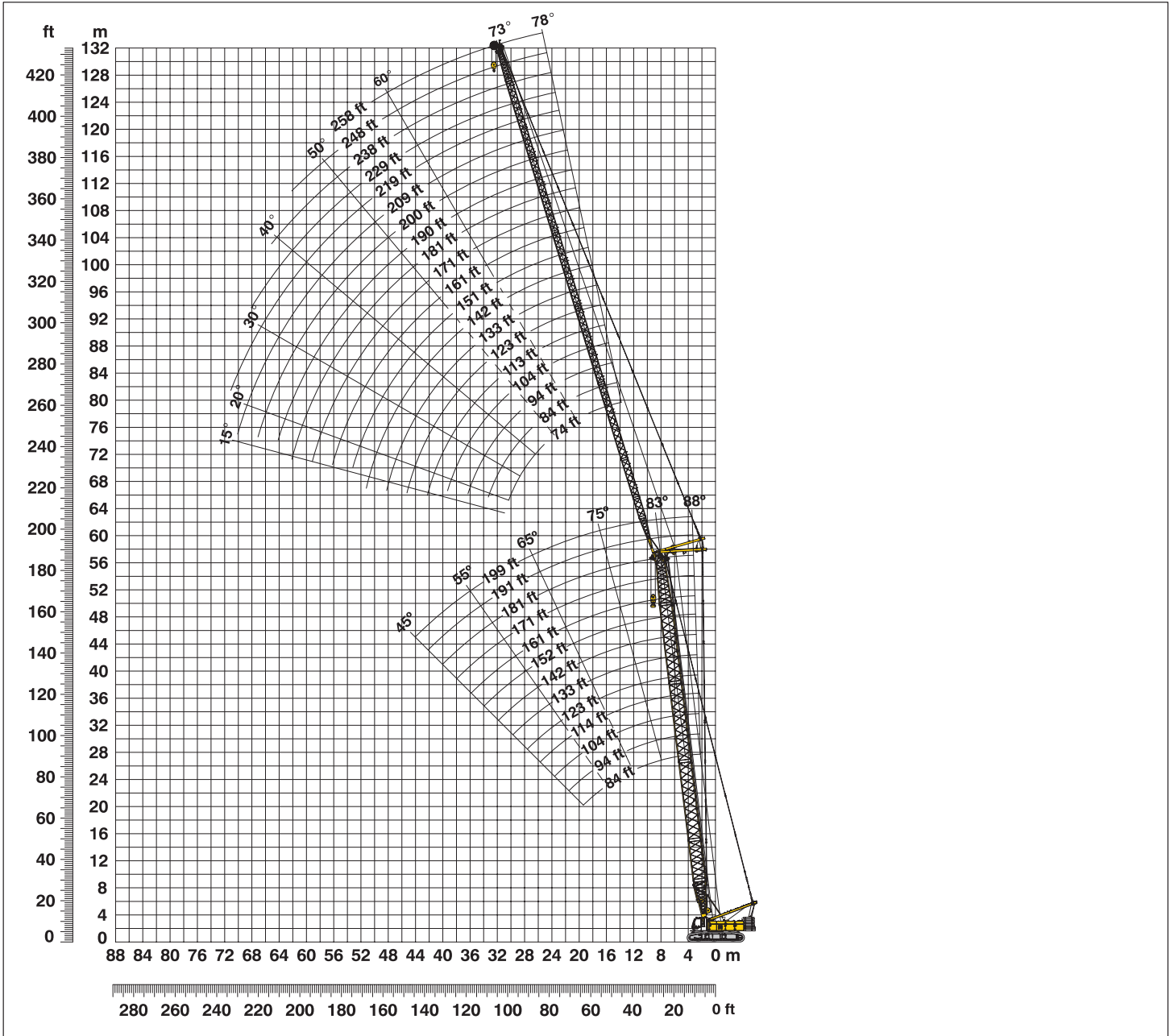

Boom configuration for main boom lengths (84 ft - 199 ft) – see table 1 on page 12

Jib configuration for jib lengths (74 ft - 258 ft)

	Length	Amount of luffing jib extensions																			
Luffing jib foot	18 ft	1	1	1	1	1	1	1	1	1	1	1	1	1	1	1	1	1	1	1	1
Luffing jib insert	10 ft*		1		1		1		1		1		1		1		1		1		1
Luffing jib insert	20 ft*			1	1			1	1			1	1			1	1			1	1
Luffing jib insert	38 ft*	1	1	1	1	2	2	2	2	3	3	3	3	4	4	4	4	5	5	5	5
Luffing jib head	18 ft	1	1	1	1	1	1	1	1	1	1	1	1	1	1	1	1	1	1	1	1
Luffing jib length (ft)		74	84	94	104	113	123	133	142	151	161	171	181	190	200	209	219	228	238	248	258

*Actual lengths of boom sections are metric (e.g. 3 m, 6 m, 11.7 m). The figures shown above are approximate conversions to feet.

Lift chart – tower crane (No. 1309.xx)

Main boom angle 88°

Main boom 84 ft

Radius (ft)	Jib length in (ft)							
	74	94	113	133	161	181	228	258
28.1	104.8							
35	104.8	90.5						
40	103.5	88.6	70.8					
45	94.5	87.0	69.5	55.8				
50	85.4	81.0	68.2	54.7	38.0			
55	72.7	72.4	66.0	53.7	37.0	29.3		
65	62.7	61.4	58.3	49.0	35.1	27.9	13.9	
70	57.0	55.1	54.3	46.5	34.2	27.2	13.6	9.1
80	47.1	47.8	45.4	41.8	32.7	25.2	13.1	8.7
100		35.4	35.3	33.7	29.1	23.0	11.9	8.2
120			26.6	26.9	22.1	21.0	11.0	7.5
135				23.2	20.6	19.4	10.8	6.9
165					17.3	15.6	10.4	6.1
185						13.4	10.0	5.6
225							8.5	5.0
255								4.4

Main boom 123 ft

Radius (ft)	Jib length in (ft)							
	74	94	113	133	161	181	228	258
29.5	100.4							
35	100.0	78.6						
40	95.7	77.0	62.9					
45	89.7	75.8	61.9	49.4				
50	83.2	74.1	60.9	48.4	34.9			
55	74.3	71.3	59.8	47.6	34.2	27.3		
65	64.5	62.7	57.5	45.6	32.7	25.3	12.7	
70	59.1	57.1	55.6	43.9	32.0	24.8	12.4	8.4
85	26.6	45.6	43.6	38.7	30.1	23.3	11.7	8.0
100		36.9	36.5	33.5	28.1	22.0	11.2	7.8
120			28.4	27.5	20.0	19.7	10.6	7.3
140				17.7	18.3	17.5	10.2	6.5
165					15.5	14.6	9.5	5.9
185						12.3	8.1	5.5
230							6.4	4.8
260								4.4

Main boom 142 ft

Radius (ft)	Jib length in (ft)							
	74	94	113	133	161	181	228	258
30.2	88.3							
35	87.9	70.8						
40	83.8	69.6	56.8					
45	76.6	67.9	56.2	44.8				
50	72.9	65.9	55.2	43.8	32.3			
55	69.3	62.9	54.0	43.0	31.8	25.2		
65	61.8	57.2	50.6	41.7	30.7	24.2	12.1	
70	58.2	54.5	49.3	40.8	30.2	23.7	11.9	8.1
85	45.3	45.6	43.7	37.4	28.5	22.4	11.2	7.6
100		37.2	36.8	32.9	26.9	21.3	10.5	7.4
120			28.7	27.5	17.8	18.9	10.0	6.9
140				15.8	16.0	16.5	9.6	6.4
165					14.1	13.7	9.0	5.8
185						12.2	7.6	5.4
230							5.8	4.7
260								4.3

Main boom 171 ft

Radius (ft)	Jib length in (ft)							
	74	94	113	133	161	181	228	258
31.5	64.1							
40	61.7	51.6	43.4					
45	59.6	50.4	42.9	35.7				
50	56.7	49.3	42.1	35.3	27.0			
55	54.0	47.7	40.9	34.8	26.8	22.0		
65	48.3	44.4	38.9	33.2	25.5	21.4	10.4	
70	46.4	42.6	37.8	32.4	25.0	21.1	10.3	7.9
80	41.7	39.4	35.8	31.0	24.1	20.3	9.9	7.1
85	38.0	38.1	34.8	30.3	23.5	20.0	9.7	6.9
100		32.2	28.9	28.1	21.0	19.0	9.4	6.1
120			15.3	14.6	15.3	16.3	9.1	5.3
140				13.3	12.8	13.6	8.3	4.8
170					9.8	10.6	6.9	4.6
190						9.3	6.5	4.4
230							5.7	3.9
260								3.7

Main boom 181 ft

Radius (ft)	Jib length in (ft)						
	74	94	113	133	161	181	219
31.9	58.9						
40	56.6	48.3	40.9				
45	54.8	47.1	40.4	33.8			
50	51.0	45.8	39.5	33.4	25.6		
55	49.2	44.5	38.5	32.8	24.8	20.4	
65	45.3	41.7	36.6	31.4	24.1	20.0	10.6
70	43.5	40.1	35.6	30.7	23.7	19.8	10.4
80	39.6	37.2	33.7	29.3	22.8	19.1	10.1
85	36.8	36.0	32.8	28.6	22.4	18.8	10.0
100		32.9	30.1	20.7	20.4	17.9	9.4
120			27.3	18.5	16.1	16.2	8.6
140				14.7	14.9	14.3	8.0
170					11.9	11.4	7.2
190						10.1	6.7
210							6.3
225							5.9

Main boom 199 ft

Radius (ft)	Jib length in (ft)					
	74	94	113	133	161	
32.2	54.1					
40	52.4	44.6				
45	50.9	43.3	37.5	28.2		
55	47.0	41.1	35.8	24.2	19.2	
60	44.8	40.2	35.0	23.6	18.5	
70	41.2	37.6	33.2	22.3	17.5	
80	37.5	34.9	31.5	20.9	16.6	
85	35.0	33.8	30.6	20.3	16.3	
90		32.6	29.8	19.8	15.9	
100		28.7	28.2	18.6	15.3	
110			15.5	17.7	14.6	
120			14.7	16.7	13.9	
130				15.8	13.2	
140				14.9	12.5	
150					11.8	
170					10.5	

Capacities in 1000 lbs with luffing jib (No. 1309.xx) 133,600 lbs counterweight + 44,100 lbs carbody counterweight. Above lift chart is for reference only. For actual lift duty and complete chart with all available configurations please refer to lift chart in operator's cab or manual.

Lift chart - luffing jib (No. 1309.xx)

Main boom angle 83°

Main boom 84 ft

Radius (ft)	Jib length in (ft)							
	74	94	113	133	161	181	228	258
41.9	104.9							
50	99.6	87.7						
55	88.2	86.0	68.5					
60	79.1	75.2	67.7	54.1				
70	65.4	64.3	60.9	50.4	35.5			
75	60.1	58.1	56.2	48.1	34.6	27.3		
90	26.6	45.8	44.0	41.2	32.2	24.8	12.9	
100		40.0	39.3	36.9	30.7	23.8	12.3	8.7
105		37.4	36.8	34.9	29.7	23.3	12.1	8.5
110			34.0	33.3	28.7	22.8	11.9	8.2
125			26.6	27.9	25.7	21.4	11.3	7.6
145				21.8	21.8	19.1	10.9	6.8
170					18.0	15.8	10.6	6.1
190						13.9	10.2	5.7
235							8.4	5.0
265								4.4

Main boom 123 ft

Radius (ft)	Jib length in (ft)							
	74	94	113	133	161	181	228	258
46.6	97.4							
55	86.9	76.1						
60	77.9	75.3	61.1					
65	70.6	70.2	60.3	47.8				
75	59.2	58.9	57.7	46.3	32.7			
80	54.8	54.4	54.1	44.7	32.1	24.6		
95	44.4	44.2	43.8	39.5	30.2	23.3	11.8	
105		39.1	38.8	36.0	29.0	22.5	11.5	8.2
110		36.9	36.7	34.3	28.3	22.1	11.3	8.1
120			32.6	31.4	27.0	21.1	11.0	7.7
130			28.9	28.0	22.9	20.2	10.7	7.3
150				19.9	20.7	17.9	10.4	6.6
175					16.8	14.5	10.0	5.9
195						12.8	9.3	5.5
240							7.7	4.8
270								4.5

Main boom 142 ft

Radius (ft)	Jib length in (ft)							
	74	94	113	133	161	181	228	258
49	83.9							
55	80.5	69.3						
65	69.9	65.4	55.6					
70	63.8	63.0	54.8	44.0				
75	58.7	58.3	53.7	43.3	30.9			
85	50.4	50.0	49.7	41.2	30.1	23.5		
95	44.0	43.7	43.4	38.6	29.0	22.6	11.4	
105		38.7	38.4	35.7	28.0	21.9	11.1	7.9
110		36.6	36.3	34.1	27.5	21.5	10.9	7.8
120			32.6	31.6	21.8	20.7	10.6	7.5
130			29.5	28.7	19.6	19.6	10.5	7.2
150				16.9	18.0	17.5	10.2	6.5
180					13.9	14.1	9.3	5.7
200						11.6	8.3	5.3
245							6.6	4.7
275								4.4

Main boom 171 ft

Radius (ft)	Jib length in (ft)							
	74	94	113	133	161	181	228	258
53.7	60.1							
60	58.1	50.5						
65	55.6	49.5	42.3					
75	50.2	46.0	41.1	34.8				
80	48.3	44.4	39.9	34.4	26.1			
85	46.8	42.8	38.6	33.7	25.3	21.3		
100	40.5	38.9	35.3	31.4	24.1	19.9	10.0	
110		35.8	33.2	29.9	23.4	19.4	9.6	6.7
120		20.5	30.8	28.4	21.2	18.8	9.5	6.1
130			28.4	27.2	18.7	17.9	9.5	5.8
135			27.0	17.9	17.6	17.3	9.4	5.7
155				14.8	16.0	15.4	9.1	5.5
185					12.3	12.6	8.1	4.9
200						11.5	7.6	4.7
245							6.6	3.8
275								3.8

Main boom 181 ft

Radius (ft)	Jib length in (ft)						
	74	94	113	133	161	181	219
54.9	54.9						
65	50.5	45.3					
70	48.5	43.7	39.1				
75	46.4	42.2	37.9	32.5			
85	43.1	39.3	35.7	31.3	24.0		
90	41.6	37.9	34.6	30.5	23.7	19.5	
100	38.8	35.7	32.6	28.9	23.0	18.9	10.6
110		33.5	30.9	27.5	22.2	18.5	10.1
120		31.9	29.3	21.0	20.4	18.0	9.7
130			28.0	20.6	18.3	17.1	9.4
140			16.1	20.1	16.9	16.2	9.1
150				17.8	16.2	15.3	8.8
160				14.0	15.5	14.4	8.6
185					13.2	12.1	8.0
205						11.0	7.6
240							7.0

Main boom 199 ft

Radius (ft)	Jib length in (ft)				
	74	94	113	133	161
55.9	50.6				
65	47.3	42.2			
70	45.5	40.9	36.3		
75	43.6	39.4	35.2	27.2	
85	40.2	36.8	33.1	24.0	18.8
90	38.9	35.5	32.1	23.5	18.2
95	37.6	34.3	31.2	23.0	17.8
100	36.4	33.4	30.3	22.4	17.5
110		31.3	28.6	21.3	16.9
120		29.2	27.3	20.2	16.3
130			18.3	19.4	15.7
140			15.9	18.4	15.0
150				17.7	14.5
160				16.9	13.8
170					13.2
185					12.6

Capacities in 1000 lbs with luffing jib (No. 1309.xx) 133,600 lbs counterweight + 44,100 lbs carbody counterweight. Above lift chart is for reference only. For actual lift duty and complete chart with all available configurations please refer to lift chart in operator's cab or manual.

Lift chart – luffing jib (No. 1309.xx)

Main boom angle 75°

Main boom 84 ft

Radius (ft)	Jib length in (ft)							
	74	94	113	133	161	181	228	258
63.2	53.0							
75	57.6	57.1						
80	53.2	52.8	52.4					
90	46.1	45.8	45.4	44.9				
100	40.6	40.3	39.9	39.5	31.6			
110		35.9	35.5	35.1	30.6	23.6		
120		32.2	31.9	31.5	28.9	22.8		
130			28.9	28.5	26.8	22.0	11.4	
135			27.6	27.2	26.5	21.5	11.4	
145				24.9	24.3	20.6	11.2	7.2
155				22.8	22.3	19.6	11.0	6.8
170					19.7	17.9	10.8	6.4
185					17.6	16.3	10.6	6.0
200						14.6	10.3	5.6
245							8.6	5.0
275								4.7

Main boom 123 ft

Radius (ft)	Jib length in (ft)							
	74	94	113	133	161	181	228	258
73.1	53.0							
85	47.4	46.9						
90	44.2	43.8	43.3					
100	38.9	38.5	38.1	37.6				
110	34.6	34.3	33.9	33.4	29.4			
120		30.8	30.4	30.0	28.8	22.1		
130		27.9	27.6	27.1	26.4	21.6		
140			25.2	24.8	24.1	20.9	10.3	
145			24.1	23.7	23.0	20.5	10.1	
155				21.7	21.1	19.8	10.0	6.8
165				20.0	19.4	18.8	9.9	6.6
180					17.3	16.8	9.6	6.1
195					15.4	15.0	9.4	5.8
210						13.4	9.1	5.4
255							8.2	4.8
285								4.6

Main boom 142 ft

Radius (ft)	Jib length in (ft)							
	74	94	113	133	161	181	228	258
78.2	51.1							
90	43.1	42.6						
95	40.3	39.9	39.4					
105	35.7	35.3	34.8	34.3				
115	26.6	31.6	31.2	30.7	27.9			
125		28.5	28.1	27.6	26.9	21.1		
130		27.1	26.8	26.2	25.6	21.1		
145			23.4	22.9	22.2	20.2	10.3	
150			22.4	22.0	21.3	19.8	10.2	
160				20.2	19.5	19.1	10.1	6.6
170				18.6	18.0	17.5	10.0	6.3
180					16.6	16.2	9.9	6.1
200					14.3	13.9	9.7	5.6
215						12.5	9.4	5.3
265							7.2	4.7
295								4.5

Main boom 171 ft

Radius (ft)	Jib length in (ft)							
	74	94	113	133	161	181	228	258
88.1	41.6							
100	35.6	35.1						
105	33.6	33.1	32.6					
115	30.0	29.6	29.1	28.6				
125	26.4	26.7	25.2	25.8	22.7			
135		24.3	23.8	23.4	22.1	18.5		
145		22.1	21.8	21.3	20.6	18.2		
155			20.0	19.5	18.8	17.7	9.3	
160			19.2	18.7	18.0	17.4	9.3	
170				17.3	16.6	16.1	9.1	5.8
180				16.0	15.3	14.8	9.0	5.6
190					14.2	13.7	8.9	5.4
205					12.7	12.2	8.7	5.2
225						10.6	8.5	4.8
275							6.5	4.2
305								4.1

Main boom 181 ft

Radius (ft)	Jib length in (ft)						
	74	94	113	133	161	181	219
90.7	39.4						
100	35.0	34.4					
110	31.2	30.6	30.1				
120	28.0	27.5	27.1	25.2			
125	26.1	25.7	25.1	24.7			
130		24.9	23.7	23.9	20.3		
140		22.7	21.8	21.6	19.7	16.8	
145		21.7	21.0	20.3	19.3	16.6	
155			19.5	19.1	18.4	16.1	9.7
165			18.0	17.6	16.9	15.6	9.5
185				15.0	14.4	13.9	9.1
210					11.9	11.5	8.7
230						9.9	8.3
265							6.9

Main boom 199 ft

Radius (ft)	Jib length in (ft)				
	74	94	113	133	161
93	37.6				
105	32.4	31.9			
110	30.6	30.1	28.1		
120	27.5	27.0	25.9	21.3	
130	24.1	24.5	24.1	20.6	17.0
140		21.9	21.9	19.7	16.4
150		19.5	19.5	18.7	15.8
160			17.5	17.9	15.2
165			16.8	17.2	14.8
170				16.5	14.5
185				14.7	13.6
190					13.3
200					12.5
215					11.2

Capacities in 1000 lbs with luffing jib (No. 1309.xx) 133,600 lbs counterweight + 44,100 lbs carbody counterweight. Above lift chart is for reference only. For actual lift duty and complete chart with all available configurations please refer to lift chart in operator's cab or manual.

Lift chart - luffing jib (No. 1309.xx)

Main boom angle 65°

Main boom 84 ft

Radius (ft)	Jib length in (ft)							
	74	94	113	133	161	181	228	258
88	44.9							
100	38.4	38.0						
110	34.2	33.8	33.4					
125		28.9	28.5	28.1				
130		27.5	27.2	26.7				
140			24.8	24.4	23.7			
150			22.7	22.3	21.6	21.1		
170				18.9	18.3	17.9		
180					16.9	16.5	10.7	
195					15.1	14.7	10.5	5.8
200					14.6	14.2	10.3	5.8
210						13.2	10.2	5.6
215						12.7	10.1	5.5
230							9.9	5.2
265							8.1	4.8
290								4.8

Main boom 123 ft

Radius (ft)	Jib length in (ft)							
	74	94	113	133	161	181	228	258
104.2	33.7							
120	28.4	27.9						
130	25.7	25.3	24.8					
140		23.0	22.6	22.1				
150		21.1	20.7	20.2				
155			19.9	19.4	18.6			
170			17.5	17.1	16.4	15.9		
185				15.2	14.6	14.1		
195					13.5	13.0	10.1	
210					12.1	11.6	9.8	5.7
215					11.7	11.2	9.7	5.5
220						10.8	9.6	5.4
235						9.7	8.7	5.2
250							7.7	5.0
280							6.1	4.7
305								4.3

Main boom 142 ft

Radius (ft)	Jib length in (ft)							
	74	94	113	133	161	181	228	258
112.6	29.1							
125	25.7	25.1						
135	23.3	22.8	22.3					
140	22.2	21.8	21.3					
150		19.9	19.5	19.0				
160		18.3	17.9	17.4				
165			17.2	16.7	15.9			
175			15.9	15.4	14.7	14.1		
195				13.2	12.5	12.0		
205					11.6	11.1	9.7	
220					10.4	9.9	8.8	5.4
240						8.6	7.5	5.1
285							5.2	4.4
315								3.3

Main boom 171 ft

Radius (ft)	Jib length in (ft)							
	74	94	113	133	161	181	228	258
128.8	21.8							
145	18.7	18.2						
155	17.1	16.7	16.2					
165		15.3	14.9	14.3				
175		14.1	13.7	13.2				
180			13.2	12.6	11.8			
190			12.2	11.7	10.9	10.2		
210				10.0	9.3	8.7		
220					8.6	8.1	6.2	
235					7.7	7.2	5.4	4.0
240						6.9	5.2	3.8
255						6.1	4.5	3.2
290							3.3	2.1
305							2.9	

Main boom 181 ft

Radius (ft)	Jib length in (ft)						
	74	94	113	133	161	181	219
132.9	20.1						
145	18.0	17.4					
155	16.5	16.0	15.4				
160	15.8	15.3	14.8				
170		14.1	13.6	13.0			
180		13.0	12.6	12.0			
185			12.1	11.5	10.6		
195			11.2	10.7	9.9	8.9	
215				9.1	8.4	7.6	
220					8.1	7.4	5.7
245					6.6	6.1	4.5
250						5.9	4.3
260						5.4	3.9
300							2.8

Main boom 199 ft

Radius (ft)	Jib length in (ft)				
	74	94	113	133	161
136.7	18.7				
150	16.6	16.0			
160	15.2	14.7	14.2		
170		13.5	13.0	12.4	
180		12.5	12.0	11.5	
190			11.1	10.6	9.5
195			10.7	10.2	9.1
200			10.3	9.8	8.8
210				9.0	8.2
215				8.7	7.9
220					7.6
230					7.0
240					6.5
245					6.2

Capacities in 1000 lbs with luffing jib (No. 1309.xx) 133,600 lbs counterweight + 44,100 lbs carbody counterweight. Above lift chart is for reference only. For actual lift duty and complete chart with all available configurations please refer to lift chart in operator's cab or manual.

Lift chart – luffing jib (No. 1309.xx)

Main boom angle 45°

Main boom 84 ft

Radius (ft)	Jib length in (ft)							
	74	94	113	133	161	181	228	258
129.5	25.1							
140	22.8							
150		20.5						
155		19.6						
161			18.3					
175			16.4					
180				15.3				
195				13.6				
205					12.0			
220					10.8	10.3		
225						10.0		
240						8.9		
260							6.7	
280							5.7	4.7
285							5.5	4.6
315								3.6

Main boom 123 ft

Radius (ft)	Jib length in (ft)							
	74	94	113	133	161	181	228	258
156.7	16.6							
165	15.6							
175		13.9						
185		12.8						
190			11.9					
200			11.1					
205				10.1				
220				9.1				
230					7.7			
240					7.1			
245					6.9	6.3		
250						6.1		
265						5.4		
285								3.4
290								3.3
310								2.6

Main boom 142 ft

Radius (ft)	Jib length in (ft)					
	74	94	113	133	161	181
170.6	13.2					
180	12.2					
190		10.8				
200		10.0				
202			9.4			
215			8.5			
220				7.7		
235				6.8		
245					5.6	
260					4.9	4.4
265					4.7	4.2
285						3.4

Main boom 171 ft

Radius (ft)	Jib length in (ft)			
	74	94	113	133
197.7	7.5			
200	7.4			
205	7.1			
215		6.0		
220		5.8		
225		5.5		
230			4.8	
240			4.4	
245			4.2	
250				3.5
260				3.1
265				2.9

Main boom 181 ft

Radius (ft)	Jib length in (ft)			
	74	94	113	133
204.7	6.2			
215	5.7			
225		4.7		
230		4.5		
238			3.7	
250			3.3	
255				2.4
265				2.1

Main boom 199 ft

Radius (ft)	Jib length in (ft)		
	74	94	113
211	5.2		
215	5.0		
220	4.8		
230		3.8	
235		3.6	
245			2.7
250			2.5
255			2.4

Capacities in 1000 lbs with luffing jib (No. 1309.xx) 133,600 lbs counterweight + 44,100 lbs carbody counterweight. Above lift chart is for reference only. For actual lift duty and complete chart with all available configurations please refer to lift chart in operator's cab or manual.

Working range - luffing jib (No. 1713.xx) 78° - 15°

Main boom 88° - 45°

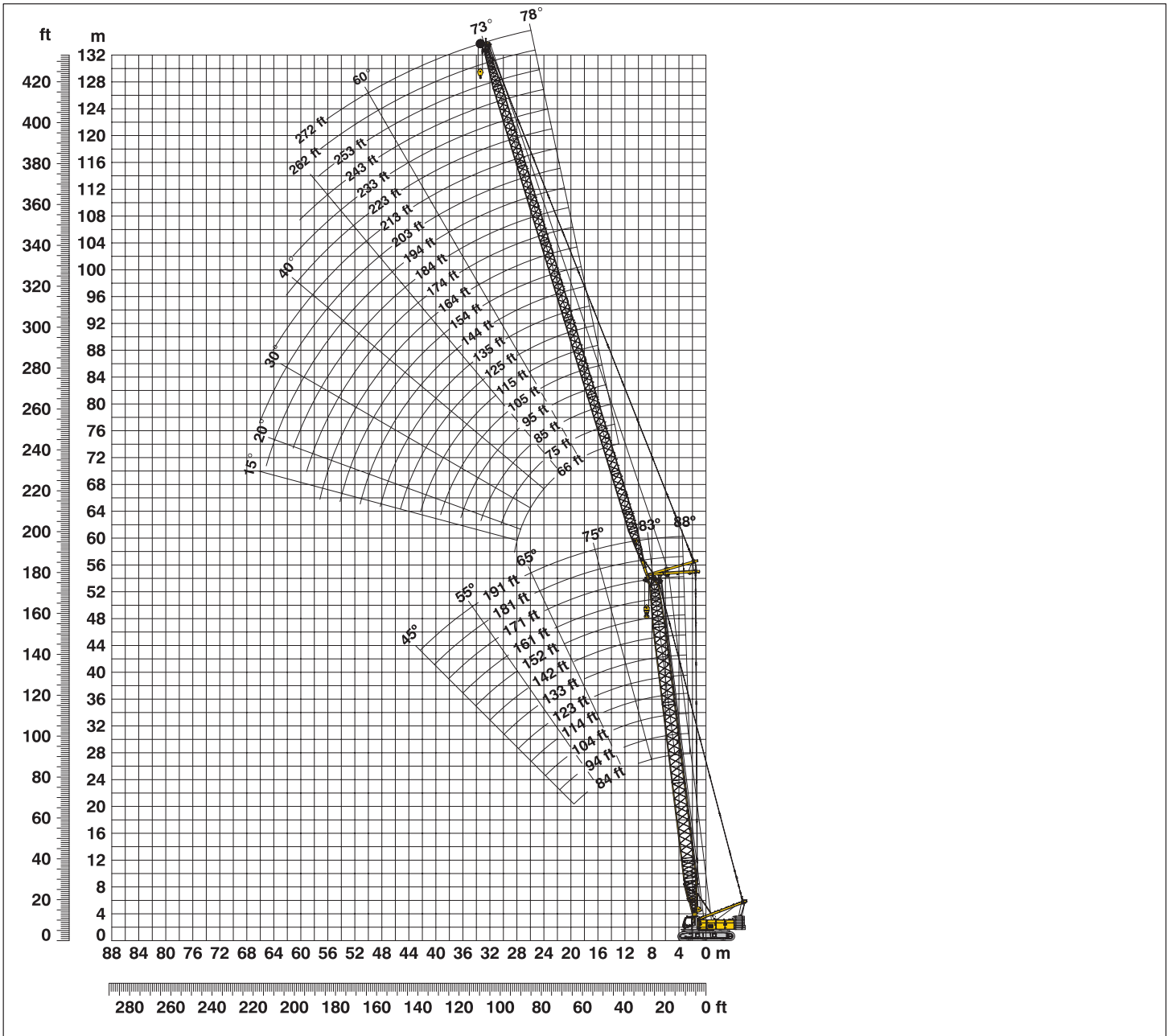

Boom configuration for main boom lengths (84 ft - 191 ft) – see table 1 on page 12

Jib configuration for jib lengths (66 ft - 272 ft)

	Length	Amount of luffing jib extensions																					
Luffing jib foot	23 ft	1	1	1	1	1	1	1	1	1	1	1	1	1	1	1	1	1	1	1	1		
Luffing jib insert	10 ft*		1		1		1		1		1		1		1		1		1		1		
Luffing jib insert	20 ft*	1	1			1	1			1	1			1	1			1	1		1		
Luffing jib insert	40 ft*			1		1	1	2	2	2	2	3	3	3	3	4	4	4	4	5	5	5	5
Luffing jib head	23 ft	1	1	1	1	1	1	1	1	1	1	1	1	1	1	1	1	1	1	1	1	1	1
Luffing jib length (ft)		66	75	85	95	105	115	125	135	144	154	164	174	184	194	203	213	223	233	243	253	262	272

*Actual lengths of boom sections are metric (e.g. 3 m, 6 m, 12 m). The figures shown above are approximate conversions to feet.

Lift chart – tower crane (No. 1713.xx)

Main boom angle 88°

Main boom 84 ft

Radius (ft)	Jib length in (ft)							
	66	95	115	135	164	184	233	272
26.3	130.5							
35	125.8	104.9						
40	112.5	104.1	91.6					
45	99.1	93.6	88.8	74.1				
50	86.8	83.5	79.9	72.9	57.0			
55	76.5	71.5	72.4	68.2	56.2	45.9		
65	61.9	60.5	58.5	57.4	50.8	43.9	27.1	
70	56.2	54.4	53.0	49.2	48.8	43.0	24.6	17.8
75	26.6	50.5	48.1	47.0	46.1	42.0	24.5	17.2
100		34.6	34.4	32.8	32.3	30.7	22.7	15.3
120			26.6	26.4	26.0	23.3	20.7	14.1
140				22.2	21.6	20.6	17.9	13.1
170					15.6	15.3	13.2	10.8
185						13.1	11.5	9.5
235							6.3	5.2
270								2.9

Main boom 123 ft

Radius (ft)	Jib length in (ft)							
	66	95	115	135	164	184	233	272
27.6	120.0							
30	118.5							
35	110.3	91.4						
40	101.0	87.9	74.9					
45	93.2	83.1	72.5	61.3				
50	85.2	76.2	69.5	60.0	45.6			
55	77.8	71.8	66.5	58.4	45.1	37.8		
65	64.8	61.9	58.3	54.5	43.7	36.9	22.6	
75	52.3	51.2	49.1	47.7	42.1	35.8	22.2	15.3
100		36.1	35.5	33.5	33.0	30.8	20.6	14.1
120			27.6	26.9	26.3	24.1	19.4	13.2
140				22.9	22.0	20.8	17.4	12.3
170					16.1	15.5	13.4	10.6
190						12.5	11.0	9.3
235							6.6	5.5
275								2.7

Main boom 142 ft

Radius (ft)	Jib length in (ft)							
	66	95	115	135	164	184	233	272
28.3	103.5							
35	95.8	77.5						
40	88.6	75.5	63.8					
45	82.2	72.2	62.7	52.6				
50	75.9	68.4	61.0	51.5	40.1			
55	71.6	64.7	58.9	50.4	39.7	33.6		
65	63.7	57.7	53.9	47.9	38.4	32.8	20.7	
75	53.6	51.0	48.2	44.8	37.0	31.8	20.4	14.2
80		48.2	45.5	43.1	36.3	31.2	20.2	14.2
100		36.6	35.8	33.8	32.6	29.0	19.0	13.2
120			28.0	27.1	26.2	24.2	17.9	12.4
140				22.9	22.2	20.9	16.4	11.6
170					16.3	15.5	13.3	10.3
190						12.7	11.2	9.3
235							6.7	5.6
275								2.9

Main boom 171 ft

Radius (ft)	Jib length in (ft)							
	66	95	115	135	164	184	233	272
29.3	78.7							
40	71.8	53.0	50.3					
45	67.3	53.0	49.7	42.3				
50	63.3	53.0	48.5	41.7	32.8			
55	59.7	51.3	47.1	40.8	32.7	27.9		
65	53.9	47.5	43.4	38.8	31.4	27.3	15.3	
75	48.0	43.0	39.8	36.4	30.2	25.6	13.7	9.8
80		41.3	38.2	35.1	29.5	25.0	13.4	9.8
100		34.8	32.6	30.6	26.9	22.9	12.2	8.9
110			29.9	28.5	24.3	21.8	11.8	8.6
120			27.5	25.4	22.8	20.7	11.4	8.3
140				22.5	20.3	18.5	10.7	7.7
170					16.3	15.2	9.6	6.9
190						12.8	8.9	6.2
235							6.4	4.7
275								2.5

Main boom 181 ft

Radius (ft)	Jib length in (ft)						
	66	95	115	135	164	184	223
29.7	72.3						
40	67.3	53.0					
45	63.2	52.4	45.7	39.1			
55	56.2	48.6	43.3	37.7	30.7	26.3	
65	49.6	43.9	40.1	35.9	29.5	25.0	14.8
70	47.4	41.9	38.2	34.8	28.9	24.6	14.6
75	45.8	39.8	36.7	33.6	28.3	24.0	14.1
80		38.2	35.3	32.5	27.6	23.5	13.6
90		35.3	32.4	30.5	25.0	22.4	13.1
100		32.8	30.5	28.4	23.8	21.3	12.5
110			28.3	26.8	22.6	20.2	12.1
120			26.2	24.4	21.2	19.2	11.6
140				21.9	19.3	17.2	10.8
170					16.2	14.9	9.5
190						12.8	8.7
225							7.1

Main boom 191 ft

Radius (ft)	Jib length in (ft)					
	66	95	115	135	164	
30	65.9					
40	61.9	49.8				
45	58.4	48.4	42.2	36.5		
55	50.7	44.8	40.0	35.3	23.1	
60	48.7	42.6	38.7	34.4	21.9	
70	44.0	38.8	35.4	32.3	20.4	
75	42.6	36.9	34.0	31.0	19.7	
80		35.4	32.7	29.7	19.1	
90		32.8	30.0	27.8	18.0	
100		31.1	28.3	25.1	16.9	
110			25.7	24.0	16.3	
120			24.9	22.7	15.6	
130				21.3	14.8	
140				20.6	14.0	
150					13.0	
170					11.2	

Capacities in 1000 lbs with luffing jib (No. 1713.xx) 133,600 lbs counterweight + 44,100 lbs carbody counterweight. Above lift chart is for reference only. For actual lift duty and complete chart with all available configurations please refer to lift chart in operator's cab or manual.

Lift chart - luffing jib (No. 1713.xx)

Main boom angle 83°

Main boom 84 ft

Radius (ft)	Jib length in (ft)							
	66	95	115	135	164	184	233	272
39.3	130.4							
50	98.9	98.2						
55	87.5	86.9	82.1					
60	78.4	74.9	75.9	69.3				
70	64.7	63.3	61.4	59.2	54.1			
75	59.4	57.3	54.8	54.0	52.0	42.9		
80	54.2	52.3	49.7	48.6	48.2	42.5		
90		45.5	42.8	42.9	41.4	38.9	23.9	
100		39.1	38.0	36.5	35.2	34.2	23.4	15.7
110		26.6	33.1	32.1	31.3	29.7	22.5	15.1
125			27.9	27.0	26.4	23.7	21.1	14.0
145				23.1	22.0	21.0	18.4	13.1
175					16.3	15.7	13.5	11.0
195						12.8	11.3	9.3
240							6.7	5.4
280								2.7

Main boom 123 ft

Radius (ft)	Jib length in (ft)							
	66	95	115	135	164	184	233	272
44	108.4							
55	86.2	83.6						
60	77.2	76.5	70.9					
65	69.8	69.1	68.6	59.9				
75	58.5	57.9	57.3	56.9	45.3			
80	54.0	53.4	52.9	51.2	45.0	37.4		
85	50.0	49.5	49.0	48.5	44.4	37.2		
95		43.2	42.7	42.3	40.7	36.0	21.4	
105		38.1	37.7	36.9	35.2	33.0	21.1	14.6
110		35.9	35.5	34.0	33.3	31.3	20.8	14.0
130			28.0	27.1	26.5	24.4	19.7	13.1
150				23.2	22.1	21.0	17.7	12.3
180					16.4	15.7	13.6	10.7
200						12.8	11.4	9.4
245							6.9	5.4
285								2.8

Main boom 142 ft

Radius (ft)	Jib length in (ft)							
	66	95	115	135	164	184	233	272
46.4	92.4							
55	85.1	70.7						
65	69.2	65.7	60.5					
70	63.1	62.4	58.3	51.0				
80	53.5	51.9	51.9	48.4	39.6			
85	49.5	49.0	48.5	46.7	39.1	33.2		
100		40.1	39.6	39.2	36.5	32.1	19.7	
110		35.5	35.1	34.7	33.8	30.6	19.3	13.1
115		26.6	33.2	32.8	32.0	29.9	19.1	13.0
120			31.5	31.1	30.1	28.7	18.9	12.9
135			26.4	26.5	26.1	17.9	18.2	12.4
150				23.2	22.6	16.0	17.0	11.8
180					17.0	12.7	13.9	10.5
200						11.7	11.5	9.6
245							7.0	5.9
285								3.0

Main boom 171 ft

Radius (ft)	Jib length in (ft)							
	66	95	115	135	164	184	233	272
49.9	70.9							
60	64.6	53.0						
65	61.4	52.1	46.4					
75	55.7	48.0	43.7	39.9				
80	51.2	46.1	42.1	38.7	31.8			
85	48.8	44.3	40.4	37.4	31.6	27.1		
90	45.4	42.3	39.0	36.3	31.0	27.0		
100		39.4	36.3	34.1	29.6	24.9	13.6	
120		26.6	30.9	29.7	24.9	22.8	12.8	9.3
130			27.8	27.4	23.7	21.0	12.5	8.9
140			25.3	25.0	22.4	19.0	12.2	8.6
155				21.8	20.5	16.7	11.8	8.2
185					16.4	13.6	10.7	7.5
205						11.7	9.7	6.9
250							6.6	4.9
290								2.5

Main boom 181 ft

Radius (ft)	Jib length in (ft)						
	66	95	115	135	164	184	223
51.1	64.8						
60	59.9	50.0					
70	53.9	46.6	42.1				
75	50.8	44.6	40.5	36.6			
80	48.8	42.7	39.0	35.5	29.5		
90	45.1	39.3	36.2	33.4	28.8	23.3	
100		36.8	33.7	31.4	27.4	22.5	14.2
110		34.3	31.6	29.5	24.2	21.5	13.7
120		31.0	29.8	27.7	23.0	20.5	13.2
130			27.6	25.2	21.8	19.6	12.9
140			25.1	23.8	20.7	18.7	12.5
150				22.6	19.9	17.7	12.1
160				20.7	19.0	17.1	11.7
185					16.3	15.3	10.8
205						13.1	10.0
245							7.2

Main boom 191 ft

Radius (ft)	Jib length in (ft)				
	66	95	115	135	164
52.3	58.6				
65	51.3	44.7			
70	49.0	42.8	38.5		
75	46.8	41.0	37.1	33.2	
85	43.1	37.7	34.4	31.2	22.3
90	41.8	36.1	33.1	30.2	21.5
95	40.7	34.8	32.0	29.2	21.0
100		33.8	30.9	28.3	20.4
110		31.6	28.9	25.3	19.5
120		30.1	27.4	24.1	18.7
130			25.2	23.1	17.7
140			24.2	22.0	16.8
150				21.0	16.2
160				20.1	15.4
170					14.6
190					12.9

Capacities in 1000 lbs with luffing jib (No. 1713.xx) 133,600 lbs counterweight + 44,100 lbs carbody counterweight. Above lift chart is for reference only. For actual lift duty and complete chart with all available configurations please refer to lift chart in operator's cab or manual.

Lift chart – luffing jib (No. 1713.xx)

Main boom angle 75°

Main boom 84 ft

Radius (ft)	Jib length in (ft)							
	66	95	115	135	164	184	233	272
59.4	53.0							
75	56.8	56.0						
85	48.6	48.0	47.4					
90	45.2	44.7	44.1	43.6				
105		36.9	36.4	35.9	35.2			
110		34.8	34.3	33.9	33.1	32.6		
120		31.1	30.7	30.3	29.6	29.0		
135			26.5	26.1	25.4	24.8	21.0	
140			25.2	24.8	24.2	23.6	20.7	
150				22.7	22.0	21.5	19.4	12.9
155				21.7	21.0	20.5	18.6	12.9
160				20.7	20.1	19.6	17.8	12.7
185					16.3	15.3	13.6	11.3
205						12.9	11.1	9.2
255							6.2	4.7
290								2.9

Main boom 123 ft

Radius (ft)	Jib length in (ft)							
	66	95	115	135	164	184	233	272
69.4	53.0							
85	46.5	45.7						
95	40.5	39.8	39.2					
100	38.0	37.3	36.7	36.2				
115		31.3	30.8	30.3	29.5			
120		29.7	29.1	28.6	27.9	27.2		
130		26.7	26.3	25.9	25.1	24.5		
145			22.8	22.4	21.6	21.1	19.4	
150			21.8	21.4	20.7	20.1	18.6	
160				19.6	18.9	18.3	16.9	12.0
170				17.9	17.3	16.8	15.3	11.9
180					15.9	15.4	14.0	11.6
195					14.1	13.6	12.2	10.7
215						11.6	10.3	8.9
265							6.5	4.9
300								3.0

Main boom 142 ft

Radius (ft)	Jib length in (ft)							
	66	95	115	135	164	184	233	272
74.5	53.0							
90	42.2	41.3						
100	37.0	36.2	35.6					
105	34.8	34.1	33.4	32.9				
120		28.8	28.2	27.7	26.9			
125		27.3	26.7	26.3	25.5	24.8		
135		24.7	24.3	23.8	23.0	22.4		
150			21.1	20.6	19.9	19.3	17.3	
155			20.1	19.7	19.0	18.4	16.5	
165				18.1	17.4	16.8	15.0	11.4
170				17.3	16.6	16.0	14.3	11.4
180					15.3	14.7	13.1	11.1
200					13.0	12.4	11.0	9.1
220						10.6	9.3	7.5
265							6.2	4.8
305								3.1

Main boom 171 ft

Radius (ft)	Jib length in (ft)							
	66	95	115	135	164	184	233	272
81.8	45.3							
95	37.7	36.7						
105	33.2	32.4	31.7					
110	31.3	30.5	29.9					
115		28.8	28.2	27.6				
125		26.0	25.4	24.8	24.0			
135		23.5	22.9	22.4	21.6	20.7		
140		22.4	21.9	21.3	20.5	19.7		
155			19.0	18.6	17.8	17.2	12.6	
160			18.2	17.8	17.0	16.4	12.6	
170				16.3	15.5	14.9	12.3	8.4
180				15.0	14.3	13.7	11.3	8.2
205					11.6	11.0	9.0	7.1
225						9.4	7.6	5.7
275							4.9	3.2
305								2.1

Main boom 181 ft

Radius (ft)	Jib length in (ft)						
	66	95	115	135	164	184	223
84.4	42.9						
100	34.7	33.8					
110	30.8	29.9	29.3				
115	29.1	28.3	27.6	27.0			
130		24.2	23.6	23.1	22.1		
135		23.0	22.5	21.9	21.0	19.8	
145		20.9	20.4	19.9	19.1	18.0	
155			18.6	18.1	17.3	16.4	12.3
165			17.0	16.6	15.8	15.1	12.1
170				15.9	15.1	14.4	11.9
180				14.6	13.9	13.3	11.2
190					12.8	12.2	10.3
210					10.8	10.3	8.6
220						9.4	7.9
230						8.7	7.3
265							5.5

Main boom 191 ft

Radius (ft)	Jib length in (ft)					
	66	95	115	135	164	
86.9	40.5					
100	34.1	33.1				
110	30.2	29.3	28.6			
120	27.0	26.3	25.6	23.3		
130		23.7	23.1	22.4	18.1	
140		21.5	20.9	20.4	17.5	
150		19.5	19.0	18.5	16.7	
160			17.4	16.9	15.9	
165			16.6	16.2	15.4	
170				15.5	14.7	
180				14.2	13.5	
185				13.6	12.9	
190					12.4	
200					11.4	
210					10.5	
215					10.1	

Capacities in 1000 lbs with luffing jib (No. 1713.xx) 133,600 lbs counterweight + 44,100 lbs carbody counterweight. Above lift chart is for reference only. For actual lift duty and complete chart with all available configurations please refer to lift chart in operator's cab or manual.

Lift chart - luffing jib (No. 1713.xx)

Main boom angle 65°

Main boom 84 ft

Radius (ft)	Jib length in (ft)							
	66	95	115	135	164	184	233	272
83	47.3							
100	37.5	36.8						
105	26.6	34.6						
115		30.8	30.3					
125		27.7	27.2	26.7				
130		26.4	25.9	25.4				
140			23.5	23.0	22.2			
150			21.4	21.0	20.2			
155				20.1	19.3	18.7		
170				17.6	16.9	16.4		
180					15.6	15.0	13.5	
200					13.2	12.7	11.3	
205						12.2	10.9	9.8
220						10.8	9.5	8.4
265							6.4	5.1
305								2.8

Main boom 123 ft

Radius (ft)	Jib length in (ft)							
	66	95	115	135	164	184	233	272
99.2	34.9							
120	27.4	26.6						
130		24.0	23.4					
140		21.8	21.2	20.6				
150		19.8	19.3	18.8				
160			17.6	17.1	16.3			
170			16.2	15.7	14.9	14.3		
190				13.3	12.6	12.0		
200					11.6	11.0	9.4	
215					10.2	9.7	8.2	
220						9.3	7.8	6.0
235						8.2	6.8	5.0
250							5.8	4.2
285							4.0	2.6
290								2.4
300								2.1

Main boom 142 ft

Radius (ft)	Jib length in (ft)							
	66	95	115	135	164	184	233	272
107.5	29.8							
125	24.7	23.7						
130	23.4	22.6						
140		20.5	19.8					
150		18.6	18.0	17.4				
160		17.0	16.5	15.9				
165			15.8	15.2	14.3			
180			13.8	13.4	12.6	11.9		
200				11.3	10.6	10.0		
205					10.1	9.5	7.5	
225					8.6	8.0	6.1	
230						7.7	5.8	3.9
245						6.7	5.0	3.1
270							3.8	2.0
295							2.9	

Main boom 171 ft

Radius (ft)	Jib length in (ft)						
	66	95	115	135	164	184	233
119.6	23.7						
140	19.3	18.4					
150		16.7	16.0				
160		15.3	14.6	13.9			
170		14.0	13.4	12.8			
180			12.2	11.7	10.8		
190			11.2	10.7	9.9	8.9	
205				9.4	8.6	7.7	
220					7.6	6.8	4.2
230					6.9	6.2	3.7
235					6.6	6.0	3.5
250						5.2	2.8
255						4.9	2.6
260							2.4
270							2.1

Main boom 181 ft

Radius (ft)	Jib length in (ft)						
	66	95	115	135	164	184	223
123.7	21.9						
145	17.7	16.8					
155		15.3	14.6				
165		14.0	13.3	12.7			
175		12.8	12.2	11.6			
185			11.1	10.6	9.5		
195			10.2	9.7	8.7	7.6	
210				8.5	7.7	6.6	
215					7.4	6.3	4.2
220					7.0	6.0	4.0
230					6.4	5.5	3.5
240					5.8	5.0	3.1
250						4.6	2.7
260						4.2	2.3
265							2.1

Main boom 191 ft

Radius (ft)	Jib length in (ft)				
	66	95	115	135	164
127.9	20.1				
145	17.0	15.9			
150	16.2	15.2			
160		13.9	13.2		
170		12.7	12.0	11.4	
180		11.6	11.0	10.4	
185			10.5	10.0	8.5
190			10.1	9.5	8.2
200			9.2	8.7	7.5
210				8.0	6.8
215				7.6	6.6
220					6.3
230					5.8
240					5.3
245					5.1

Capacities in 1000 lbs with luffing jib (No. 1713.xx) 133,600 lbs counterweight + 44,100 lbs carbody counterweight. Above lift chart is for reference only. For actual lift duty and complete chart with all available configurations please refer to lift chart in operator's cab or manual.

Lift chart – luffing jib (No. 1713.xx)

Main boom angle 45°

Main boom 84 ft

Radius (ft)	Jib length in (ft)						
	66	95	115	135	164	184	233
122.3	26.0						
130	24.1						
150		19.2					
160		17.5					
165			16.3				
180			14.3	13.8			
195				12.2			
205					10.6		
220					9.3	8.7	
225					8.9	8.4	
240						7.4	
245						7.0	
260							4.7
270							4.3
280							3.8
290							3.4

Main boom 123 ft

Radius (ft)	Jib length in (ft)					
	66	95	115	135	164	184
149.5	16.7					
155	15.9					
175		12.4				
185		11.5				
190			10.3			
205			9.1			
210				8.2		
225				7.2		
235					5.8	
240					5.5	
245					5.3	
250					5.0	4.4
255						4.2
260						3.9
265						3.7
270						3.5

Main boom 142 ft

Radius (ft)	Jib length in (ft)					
	66	95	115	135	164	184
163.4	12.9					
170	12.2					
190		9.4				
200		8.6				
205			7.5			
215			6.9			
220				6.0		
235				5.2		
244					3.9	
265					3.1	2.3
275						2.0

Main boom 171 ft

Radius (ft)	Jib length in (ft)			
	66	95	115	135
183.6	8.3			
185	8.2			
190	7.9			
210		5.6		
215		5.3		
225			4.1	
230			3.9	
235			3.7	
240				2.7
250				2.4
255				2.3

Capacities in 1000 lbs with luffing jib (No. 1713.xx) 133,600 lbs counterweight + 44,100 lbs carbody counterweight. Above lift chart is for reference only. For actual lift duty and complete chart with all available configurations please refer to lift chart in operator's cab or manual.

Working range - fixed jib (No. 0806.xx) 15° and 30°

Main boom 88°- 30°

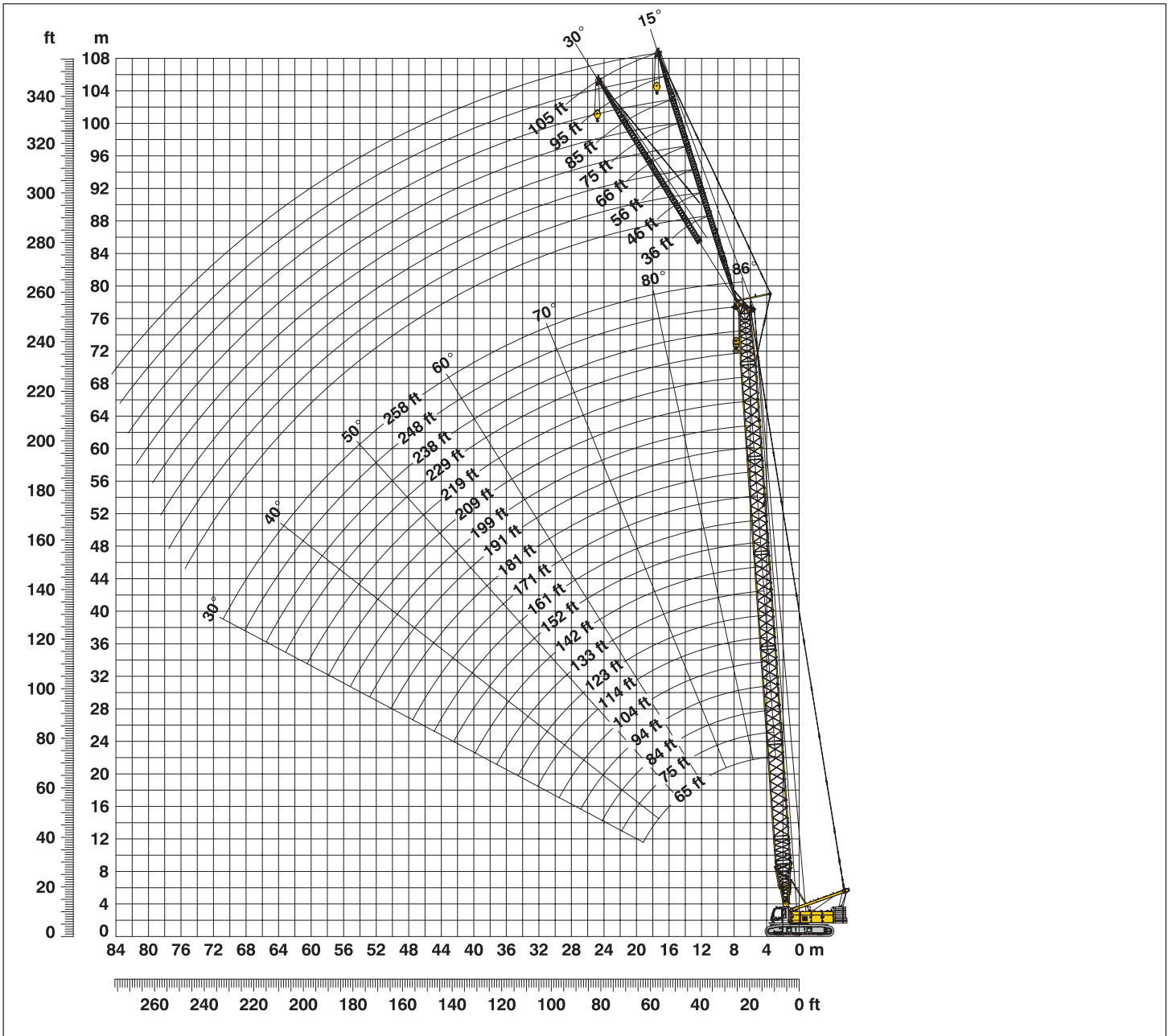

Boom configuration for boom lengths (66 ft - 258 ft) – see table 1 on page 12

Fixed jib configuration for fixed jib lengths (36 ft - 105 ft)

	Length	Amount of fixed jib extensions								
Fixed jib foot	18 ft	1	1	1	1	1	1	1	1	1
Fixed jib insert	10 ft*		1		1		1		1	1
Fixed jib insert	20 ft*			1	1	2	2	3	3	
Fixed jib head	18 ft	1	1	1	1	1	1	1	1	1
Fixed jib length (ft)		36	46	56	66	75	85	95	105	

*Actual lengths of boom sections are metric (e.g. 3 m, 6 m). The figures shown above are approximate conversions to feet.

Lift chart - fixed jib (No. 0806.xx)

Offset 15°

Main boom 66 ft

Radius (ft)	Fixed jib length in (ft)			
	36	66	85	105
25	53.0			
35	53.0	37.9		
40	53.0	36.8	23.1	
50	53.0	34.7	20.3	12.5
60	53.0	32.4	19.2	11.9
70	50.4	30.0	17.9	11.3
80	44.9	27.4	16.7	10.7
90	40.7	24.9	16.0	10.3
95	38.8	24.1	15.7	10.1
125		19.7	14.1	9.2
145			13.6	8.8
165				8.8

Main boom 94 ft

Radius (ft)	Fixed jib length in (ft)			
	36	66	85	105
20.3	53.0			
35	53.0	38.4		
45	53.0	36.6	21.3	
50	53.0	35.8	20.9	12.4
60	53.0	34.1	20.0	11.9
70	53.0	32.3	19.0	11.4
80	52.7	30.4	18.0	10.9
100	39.4	25.6	16.3	10.1
120	30.7	23.2	15.1	9.6
150		19.9	14.0	8.9
170			13.6	8.6
190				8.6

Main boom 133 ft

Radius (ft)	Fixed jib length in (ft)			
	36	66	85	105
21.6	53.0			
35	53.0	37.4		
45	53.0	36.2	20.9	
55	53.0	34.9	20.2	12.1
80	51.9	31.8	18.1	11.1
100	38.4	29.0	16.8	10.4
120	29.8	25.2	15.8	9.8
140	23.8	23.3	14.8	9.4
155	20.3	21.4	14.4	9.0
185		16.1	13.6	8.6
205			13.2	8.5
225				8.5

Main boom 171 ft

Radius (ft)	Fixed jib length in (ft)			
	36	66	85	105
23	53.0			
40	53.0	35.4		
45	53.0	35.0	19.6	
55	53.0	34.0	19.4	12.0
60	53.0	33.6	19.2	11.8
80	50.9	31.7	18.0	11.1
120	28.7	27.8	16.0	10.0
160	18.2	19.4	14.5	9.2
190	13.3	14.4	13.7	8.7
215		11.3	11.8	8.4
235			9.8	8.2
255				8.0

Main boom 191 ft

Radius (ft)	Fixed jib length in (ft)			
	36	66	85	105
23.6	53.0			
40	53.0	34.5		
45	53.0	34.2	19.5	
55	53.0	33.3	19.3	12.0
80	50.3	31.2	17.9	11.1
120	28.0	28.1	16.1	10.1
160	17.6	18.8	14.6	9.3
200	11.4	12.5	13.0	8.7
205	10.8	11.8	12.4	8.6
235		8.7	9.2	8.3
255			7.5	8.0
275				6.5

Main boom 219 ft

Radius (ft)	Fixed jib length in (ft)			
	36	66	85	105
24.6	53.0			
40	53.0	31.8		
50	53.0	31.5	18.8	
55	52.5	31.2	18.5	11.8
80	49.3	29.4	17.2	11.1
120	27.2	26.9	15.6	10.1
160	16.8	18.0	14.5	9.3
200	10.6	11.6	12.3	8.7
230	7.4	8.4	8.9	8.1
260		5.8	6.3	6.8
280			4.9	5.4
300				4.1

Main boom 238 ft

Radius (ft)	Fixed jib length in (ft)			
	36	66	85	105
25.3	53.0			
40	51.9	30.6		
50	50.3	30.1	18.4	
55	49.5	29.8	18.1	11.4
80	45.6	28.1	16.8	10.7
120	26.7	23.1	15.4	9.8
160	16.2	17.4	14.3	9.1
200	10.0	11.1	11.7	8.5
245	5.5	6.5	7.0	7.5
275		4.2	4.7	5.2
295			3.4	3.9
315				2.7

Main boom 248 ft

Radius (ft)	Fixed jib length in (ft)			
	36	66	85	105
25.6	50.6			
40	49.1	30.0		
50	47.4	29.6	18.1	
55	46.6	29.2	17.9	11.3
80	42.6	27.4	16.6	9.8
120	26.3	22.9	15.2	9.3
160	15.8	17.1	14.2	8.2
200	9.7	10.8	11.4	7.8
255	4.4	5.3	5.9	6.4
285		3.2	3.7	4.2
305			2.5	3.0
320				2.2

Main boom 258 ft

Radius (ft)	Fixed jib length in (ft)			
	36	46	66	75
26	48.4			
35	47.6	40.4		
40	46.8	39.9	28.4	
45	46.0	39.3	28.1	19.4
80	40.0	34.7	24.2	19.1
120	26.1	26.6	22.1	18.0
160	15.5	16.0	16.8	16.9
200	9.4	9.7	10.5	10.8
265	3.4	3.7	4.3	4.6
275		3.0	3.6	3.9
295			2.3	2.6
305				2.0

Capacities in 1000 lbs with luffing jib (No. 0806.xx) 133,600 lbs counterweight + 44,100 lbs carbody counterweight. Above lift chart is for reference only. For actual lift duty and complete chart with all available configurations please refer to lift chart in operator's cab or manual.

Lift chart - fixed jib (No. 0806.xx)

Offset 30°

Main boom 66 ft

Radius (ft)	Fixed jib length in (ft)			
	36	66	85	105
30	53.0			
50	50.8	30.0		
60	46.3	27.3	18.3	
75	40.1	23.8	15.5	10.0
80	38.6	22.8	15.2	9.9
85	37.0	22.1	14.9	9.7
90	35.9	21.4	14.7	9.5
95	35.2	20.7	14.4	9.4
100	34.3	20.1	14.1	9.3
130		18.2	13.2	8.7
150			12.9	8.6
170				8.6

Main boom 94 ft

Radius (ft)	Fixed jib length in (ft)			
	36	66	85	105
29.1	53.0			
50	53.0	31.1		
65	48.1	27.6	16.5	
75	44.7	25.3	15.8	10.0
80	42.9	24.6	15.5	9.9
90	40.0	23.1	15.1	9.6
100	37.8	21.9	14.6	9.3
110	35.0	20.8	14.2	9.1
120	30.9	20.0	13.9	9.0
150		18.5	13.2	8.6
170			13.1	8.6
190				8.6

Main boom 133 ft

Radius (ft)	Fixed jib length in (ft)			
	36	66	85	105
30.4	53.0			
50	53.0	30.8		
65	51.5	28.3	16.5	
75	48.5	26.7	15.9	10.5
80	47.0	25.3	15.6	9.8
100	39.0	23.1	14.7	9.4
120	30.2	21.3	14.0	9.0
140	24.0	19.9	13.5	8.8
155	20.5	19.1	13.2	8.6
185		16.3	12.9	8.5
205			12.9	8.4
225				8.0

Main boom 171 ft

Radius (ft)	Fixed jib length in (ft)			
	36	66	85	105
31.7	53.0			
55	52.8	29.7		
65	52.3	28.6	16.1	
80	49.7	26.7	15.5	9.3
120	29.2	22.2	14.2	8.3
140	23.1	21.0	13.7	8.3
160	18.5	19.8	13.3	8.3
180	15.0	16.3	13.0	8.3
190	13.5	14.7	12.9	8.3
215		11.4	12.2	8.3
235			9.9	8.3
255				8.3

Main boom 191 ft

Radius (ft)	Fixed jib length in (ft)			
	36	66	85	105
32.4	53.0			
55	52.5	29.1		
65	51.4	28.5	16.0	
80	49.5	26.9	15.5	9.5
120	28.7	22.4	14.2	8.5
160	18.0	19.4	13.3	8.5
180	14.4	15.8	13.0	8.3
200	11.6	12.8	12.8	8.2
205	11.0	12.2	12.8	8.2
235		8.8	9.5	8.2
255			7.6	8.2
275				6.6

Main boom 219 ft

Radius (ft)	Fixed jib length in (ft)			
	36	66	85	105
33.4	50.6			
55	49.3	27.3		
65	48.4	26.8	16.9	
80	47.0	23.2	14.9	9.4
120	27.9	21.8	14.0	8.9
160	17.2	18.7	13.2	8.5
200	10.8	12.1	12.6	8.2
220	8.5	9.7	10.5	8.1
230	7.5	8.7	9.4	8.1
260		5.9	6.6	7.2
280			5.0	5.6
300				4.2

Main boom 238 ft

Radius (ft)	Fixed jib length in (ft)			
	36	66	85	105
34.1	47.5			
55	46.3	23.7		
70	44.7	23.1	15.0	
80	43.7	22.6	14.8	9.3
120	27.4	21.2	13.8	8.8
160	16.7	18.3	13.1	8.4
200	10.3	11.7	12.4	8.1
240	6.1	7.2	7.9	8.0
245	5.6	6.8	7.5	8.0
275		4.3	5.0	5.6
295			3.5	4.2
315				2.8

Main boom 248 ft

Radius (ft)	Fixed jib length in (ft)			
	36	66	85	105
34.4	44.9			
55	43.0	23.7		
70	41.0	23.1	14.9	
80	39.7	22.6	14.6	8.9
120	27.1	21.2	13.8	8.3
160	16.4	18.0	13.1	8.0
200	10.0	11.4	12.2	7.8
240	5.8	6.9	7.7	7.6
255	4.5	5.6	6.3	7.0
285		3.3	4.0	4.6
305			2.6	3.3
320				2.3

Main boom 258 ft

Radius (ft)	Fixed jib length in (ft)			
	36	46	66	
26	48.4			
35	47.6	40.4		
40	46.8	39.9	28.4	
60	43.5	37.2	27.0	
80	40.0	34.7	24.2	
120	26.1	26.6	22.1	
160	15.5	16.0	16.8	
200	9.4	9.7	10.5	
240	5.3	5.6	6.3	
265	3.4	3.7	4.3	
275		3.0	3.6	
295			2.3	

Capacities in 1000 lbs with luffing jib (No. 0806.xx) 133,600 lbs counterweight + 44,100 lbs carbody counterweight. Above lift chart is for reference only. For actual lift duty and complete chart with all available configurations please refer to lift chart in operator's cab or manual.

Working range - fixed jib (No. 1008.xx) 15° and 30°

Main boom 88°- 30°

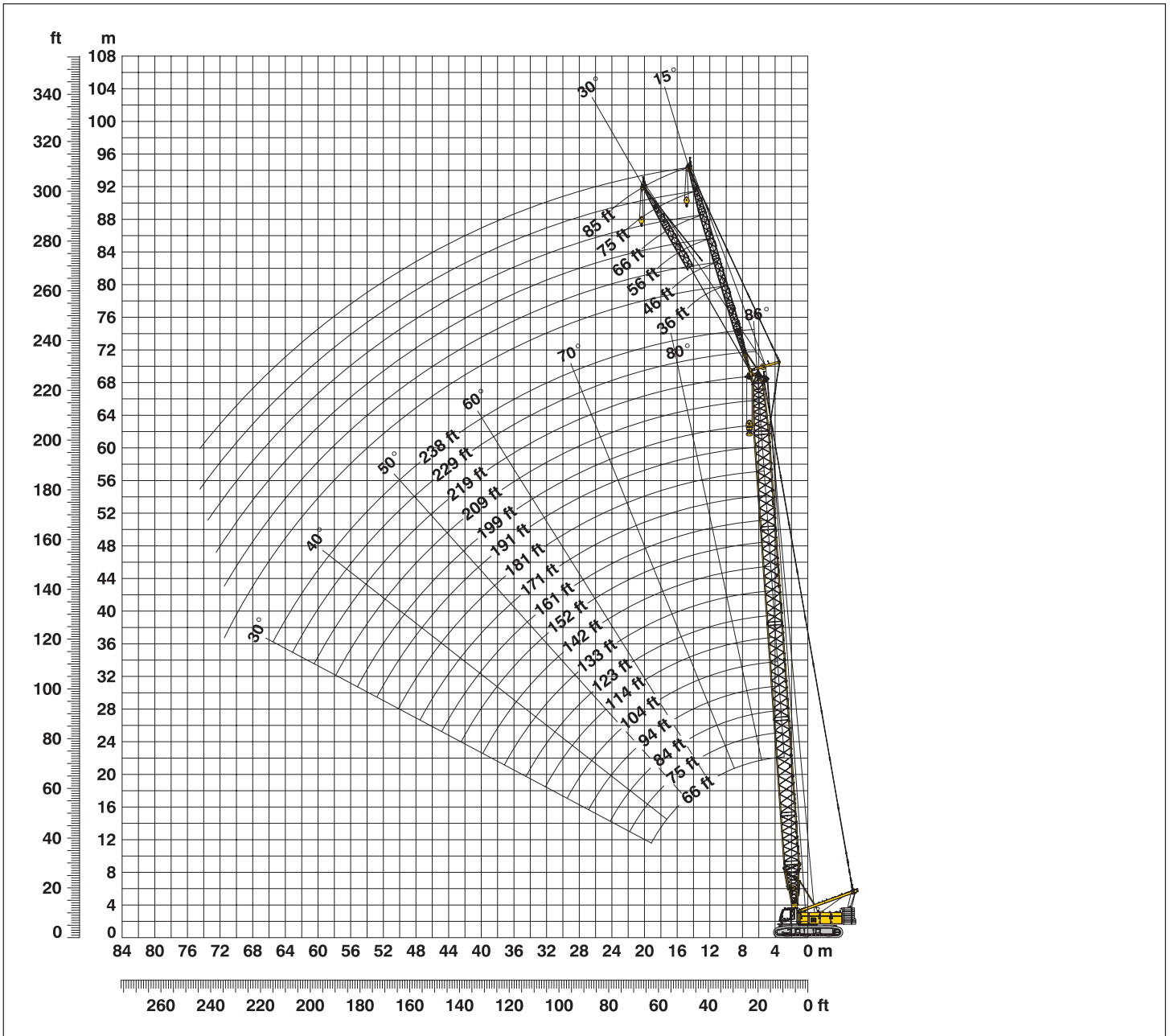

Boom configuration for boom lengths (66 ft - 238 ft) – see table 1 on page 12

Fixed jib configuration for fixed jib lengths (36 ft - 85 ft)

	Length	Amount of fixed jib extensions					
Fixed jib foot	18 ft	1	1	1	1	1	1
Fixed jib insert	10 ft*		1		1		1
Fixed jib insert	20 ft*			1	1	2	2
Fixed jib head	18 ft	1	1	1	1	1	1
Fixed jib length (ft)		36	46	56	66	75	85

*Actual lengths of boom sections are metric (e.g. 3 m, 6 m). The figures shown above are approximate conversions to feet.

Lift chart - fixed jib (No. 1008.xx)

Offset 15°

Main boom 66 ft

Radius (ft)	Fixed jib length in (ft)			
	36	46	66	85
18.5	79.1			
25	79.1	79.1		
30	79.1	79.0	59.4	
40	78.6	70.1	51.9	42.8
50	77.2	61.4	46.7	37.8
60	75.5	56.9	41.6	33.8
70	61.6	55.9	37.5	30.4
80	51.7	51.0	37.1	27.4
95	40.9	41.5	34.8	26.6
105		36.1	31.9	26.4
125			27.7	23.0
145				20.4

Main boom 94 ft

Radius (ft)	Fixed jib length in (ft)			
	36	46	66	85
19.4	79.1			
25	79.1	78.0		
35	79.1	74.6	62.7	
40	79.1	73.1	60.2	45.0
50	79.1	70.2	55.2	42.1
60	74.9	66.9	51.5	39.1
80	51.0	51.5	42.8	33.0
100	37.5	37.9	38.1	28.4
120	28.8	29.2	29.9	26.3
130		25.9	26.6	25.0
150			21.3	21.8
170				17.8

Main boom 133 ft

Radius (ft)	Fixed jib length in (ft)			
	36	46	66	85
20.8	79.1			
25	79.1	79.1		
35	79.1	78.2	68.1	
45	79.1	75.4	64.9	45.7
60	74.0	70.2	57.5	42.9
80	49.9	50.5	49.0	37.8
120	27.7	28.1	28.8	28.7
140	21.7	22.0	22.7	23.2
155	18.2	18.5	19.2	19.6
165		16.5	17.2	17.6
185			13.8	14.3
205				11.5

Main boom 152 ft

Radius (ft)	Fixed jib length in (ft)			
	36	46	66	85
21.5	79.1			
30	79.1	78.8		
35	79.1	78.0	65.9	
45	79.1	74.7	63.1	44.5
60	73.5	70.4	56.8	42.1
80	49.4	49.9	49.2	38.2
120	27.1	27.5	28.2	28.8
160	16.6	16.9	17.5	18.0
170	14.8	15.1	15.6	16.1
180		13.4	14.0	14.4
200			11.1	11.6
220				9.2

Main boom 171 ft

Radius (ft)	Fixed jib length in (ft)			
	36	46	66	85
22.1	79.1			
30	79.1	75.7		
35	79.1	75.5	60.9	
45	79.1	73.3	59.9	42.7
60	73.1	69.3	55.1	40.9
80	48.9	49.5	47.9	37.8
120	26.6	27.0	27.7	28.4
160	16.1	16.4	17.0	17.5
190	11.2	11.4	12.0	12.4
200		10.1	10.6	11.1
215			8.8	9.3
235				7.2

Main boom 191 ft

Radius (ft)	Fixed jib length in (ft)			
	36	46	66	85
22.8	79.1			
30	79.1	72.4		
35	78.9	72.1	55.9	
45	78.2	70.2	55.8	40.4
80	48.3	48.9	46.3	36.6
120	26.0	26.4	27.1	27.8
160	15.4	15.7	16.4	16.9
200	9.2	9.5	10.0	10.4
205	8.6	8.9	9.4	9.8
215		7.7	8.2	8.7
235			6.2	6.6
255				4.8

Main boom 219 ft

Radius (ft)	Fixed jib length in (ft)			
	36	46	66	85
23.8	67.5			
30	67.0	59.8		
40	65.2	59.2	46.0	
45	64.0	58.2	46.0	36.3
80	47.6	48.2	41.3	33.8
120	25.1	25.5	26.4	27.1
160	14.6	14.9	15.5	16.1
200	8.4	8.6	9.2	9.6
230	5.2	5.4	5.8	6.3
240		4.5	4.9	5.3
260			3.3	3.6
280				2.2

Main boom 229 ft

Radius (ft)	Fixed jib length in (ft)			
	36	46	56	66
24.2	62.1			
30	61.6	54.7		
35	60.8	54.3	47.2	
40	59.6	53.8	47.2	42.3
80	47.3	45.5	42.2	38.8
120	24.8	25.2	25.7	26.1
160	14.2	14.5	14.9	15.2
200	8.0	8.3	8.6	8.8
235	4.4	4.6	4.9	5.0
245		3.7	4.0	4.2
255			3.2	3.3
265				2.6

Main boom 238 ft

Radius (ft)	Fixed jib length in (ft)			
	36	46		
25.4	53.0			
30	53.0	50.3		
40	53.0	50.1		
60	51.2	47.1		
80	45.7	42.3		
120	24.6	25.0		
160	14.0	14.3		
200	7.8	8.0		
220	5.6	5.8		
240	3.7	3.9		
245	3.3	3.5		
255		2.7		

Capacities in 1000 lbs with luffing jib (No. 1008.xx) 133,600 lbs counterweight + 44,100 lbs carbody counterweight. Above lift chart is for reference only. For actual lift duty and complete chart with all available configurations please refer to lift chart in operator's cab or manual.

Lift chart - fixed jib (No. 1008.xx)

Offset 30°

Main boom 66 ft

Radius (ft)	Fixed jib length in (ft)			
	36	46	66	85
27.2	70.2			
35	64.8	52.8		
50	56.3	46.1	33.9	
60	53.2	42.4	31.2	25.6
70	53.0	40.5	28.8	23.6
80	50.2	40.0	26.8	22.0
90	44.4	37.6	26.6	20.5
95	41.2	36.2	26.6	19.8
100	38.3	35.2	26.4	19.4
110		34.0	25.1	18.9
130			23.1	17.3
150				16.2

Main boom 94 ft

Radius (ft)	Fixed jib length in (ft)			
	36	46	66	85
29.6	79.1			
40	78.5	64.8		
50	74.8	61.5	42.2	
60	68.5	57.1	39.2	28.4
80	50.9	50.1	34.1	26.6
100	37.0	37.6	30.4	23.6
120	28.2	28.7	27.6	21.2
140	22.0	22.4	23.3	19.4
155	18.3	18.8	19.6	18.2
165		16.7	17.5	17.6
185			13.9	14.7
205				11.7

Main boom 133 ft

Radius (ft)	Fixed jib length in (ft)			
	36	46	66	85
30.2	79.1			
40	78.4	64.6		
50	74.8	61.5	41.9	
65	67.0	55.7	38.1	28.2
80	50.4	50.7	34.8	25.9
120	27.6	28.2	28.5	21.9
140	21.4	21.9	22.8	20.1
160	16.8	17.2	18.1	18.3
175	14.0	14.4	15.2	15.9
185		12.7	13.5	14.2
205			10.6	11.3
225				8.8

Main boom 152 ft

Radius (ft)	Fixed jib length in (ft)			
	36	46	66	85
29.7	79.1			
40	78.2	64.5		
50	74.5	61.3	41.9	
65	64.0	55.5	37.7	27.9
100	34.4	35.1	31.0	24.0
120	26.0	26.6	27.5	21.8
140	20.1	20.5	21.5	20.0
160	15.6	16.0	16.9	17.6
170	13.8	14.2	15.0	15.7
180		12.5	13.3	14.0
200			10.3	11.0
220				8.5

Main boom 171 ft

Radius (ft)	Fixed jib length in (ft)			
	36	46	66	85
30.9	78.4			
40	77.9	63.3		
50	72.4	60.5	40.6	
65	66.2	55.2	38.4	28.2
80	50.0	50.8	35.2	23.9
120	27.2	27.7	28.8	22.1
160	16.4	16.8	17.6	18.4
180	12.8	13.2	13.9	14.6
190	11.3	11.6	12.4	13.0
200		10.2	10.9	11.6
220			8.4	9.0
235				7.4

Main boom 291 ft

Radius (ft)	Fixed jib length in (ft)			
	36	46	66	85
31.6	73.9			
40	72.7	60.8		
50	68.5	58.2	40.0	
65	63.2	53.5	38.5	27.9
80	49.6	49.8	35.5	21.5
120	26.6	27.2	28.4	21.3
160	15.8	16.2	17.1	17.9
200	9.4	9.7	10.4	11.1
205	8.7	9.1	9.8	10.4
215		7.9	8.5	9.1
235			6.3	6.9
255				5.0

Main boom 219 ft

Radius (ft)	Fixed jib length in (ft)			
	36	46	66	85
32.6	61.9			
40	61.2	53.5		
55	57.8	50.5	38.1	
65	55.3	48.4	37.0	27.2
80	49.0	45.4	34.5	18.9
120	25.9	26.5	27.8	18.9
160	15.0	15.5	16.4	17.2
200	8.6	9.0	9.7	10.4
230	5.3	5.5	6.2	6.8
240		4.6	5.2	5.8
260			3.4	3.9
280				2.3

Main boom 229 ft

Radius (ft)	Fixed jib length in (ft)			
	36	46	56	66
32.9	56.3			
40	56.3	47.7		
50	55.1	47.2	40.7	
55	53.9	46.6	40.7	36.2
80	47.8	42.8	37.9	33.7
120	25.6	26.2	26.9	27.5
160	14.7	15.2	15.7	16.1
200	8.3	8.7	9.1	9.4
240	4.0	4.3	4.6	4.9
250		3.4	3.7	4.0
260			2.9	3.1
270				2.3

Main boom 238 ft

Radius (ft)	Fixed jib length in (ft)			
	36	46		
34.2	51.9			
45	51.2	44.7		
60	48.2	43.3		
80	43.5	39.3		
120	25.4	26.1		
160	14.5	15.0		
180	10.9	11.3		
200	8.1	8.4		
220	5.8	6.1		
240	3.8	4.1		
245	3.4	3.6		
255		2.8		

Capacities in 1000 lbs with luffing jib (No. 1008.xx) 133,600 lbs counterweight + 44,100 lbs carbody counterweight. Above lift chart is for reference only. For actual lift duty and complete chart with all available configurations please refer to lift chart in operator's cab or manual.

